

Phase-Resolved PD Analysis Plot
This plot shows phase-to-phase discharge activity caused by end-arm contamination.

A Powerful Diagnostic Technique That Can Be Conducted On- or Off-line for Condition-based Maintenance and Outage Avoidance

Partial Discharge Analysis (PDA) is a non-destructive and non-invasive technique for monitoring the integrity of the stator insulation systems in rotating machines. PDA testing during machine operation is useful for identifying potentially catastrophic deterioration phenomena such as slot discharge, internal voids, delaminations as well as winding looseness.

obtained leading to failure of the equipment.

Your GE Solution

GE provides a wide variety of installation and testing options for Partial Discharge measurements. Using phase-resolved data acquisition, insulation experts can remotely monitor equipment and tailor a testing plan to meet the customer's needs.

What Causes PD?

- Insulation delamination/damage
- End winding contamination
- Damage to end winding voltage suppresser system
- Stator bar vibration
- Broken conductor strands

What is Partial Discharge?

Partial discharges are electrical "sparks" that do not completely bridge the electrodes and which exist in nearly all high voltage electrical machinery. The phenomena results in high frequency, low voltage signals on the phase leads. Over time, the degradation and discharges become larger until a full discharge is

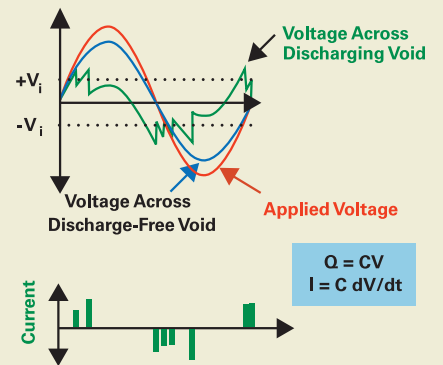

PARTIAL DISCHARGE ANALYSIS

PDA

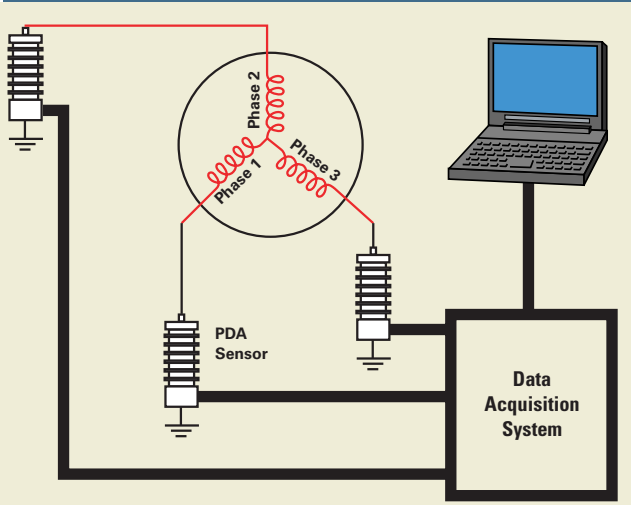

Couplers meet all applicable electrical standards and safely allow GE to regularly monitor the condition of your installation system.

GE Solutions: Tailored to Meet Your Needs

- Installation kits, including PDA sensors and termination boxes for your motors and generators
- Supervision of installation
- On-line local or remote data acquisition and analysis
- Continuous On-line Monitor (PDA-COMpact)
- Data analysis services compatible with other manufacturers' equipment
- Customer training

The GE Approach

Feature	Your GE Advantage
GE's sensors allows us to monitor the entire machine winding.	Superior to slot-style couplers (e.g., SCC's) which provide limited coverage to the top bar (or two) per phase.
Installation can be done in less than one day during a minor outage.	Far less expensive than competitor methods which may require removal of the field to install the sensors.
GE uses phase-resolved PDA with sophisticated pattern analysis.	We go beyond simple trending of measured and integrated quantities (e.g., NQN) to more accurately identify defects.

For more information, contact your local GE representative.



GE Energy Services

A GE Power Systems Business
4200 Wildwood Parkway
Atlanta, GA 30339
1-800-4GE-FAST

GEA 12307B 5M 07/01