

GE Energy

# ■ ROOF-INTEGRATED SOLAR ELECTRIC POWER SYSTEMS



imagination at work

## OUTSTANDING WITHOUT STANDING OUT

Generate solar electric power at home with roof-integrated solar systems by GE Energy. Roof-integrated solar systems are designed to seamlessly blend into the profile of a concrete roof tile, replacing the tiles and generating electricity in the process. This approach simplifies installation, reduces installation cost and enables the solar power array to integrate into the finished roof.

## FEATURES & BENEFITS

- 18 single-crystal cells connected in series
- Peak power of 55 Watts at 8.4 Volts
- Unique interlocking design
- Faster installation time than alternate solar system mounting technologies
- Rugged extruded aluminum and tempered glass construction
- Worry-free operation with virtually no maintenance
- 25-year limited warranty on power output, 5-year limited warranty on materials and workmanship\*

\*Refer to GE Energy Product Warranty for specific details

## THE COMPLETE SYSTEM FROM GE ENERGY

GE Energy provides complete solar electric power systems. Systems featuring roof-integrated solar electric power modules generate clean, renewable electricity and operate silently, automatically, and reliably for years without fuel or moving parts. These systems include quick connect wiring, power electronics, a power meter to monitor performance, and complete documentation for homebuilders, contractors, installers, and homeowners.



### 25-Year Warranty

Roof-integrated solar electric modules have a 25-year limited warranty on power output and a 5-year limited warranty on materials and workmanship.

### Ease of Installation

Systems featuring roof-integrated solar electric power modules are designed to integrate seamlessly into the construction process.

### Manage Power Usage

GE Energy's solar electric power system meter allows real-time monitoring of system performance and overall electrical usage of a home.

## OUTPUT AND SYSTEM SPECIFICATIONS

Every GE Energy solar electric power system is engineered for maximum performance. System performance will vary according to geographic location, weather fluctuations, roof orientation, amount of direct sunlight, and other influencing factors. The following chart uses simulation calculations and optimal conditions to illustrate regional power output levels per kW of generation using GE solar electric power systems.

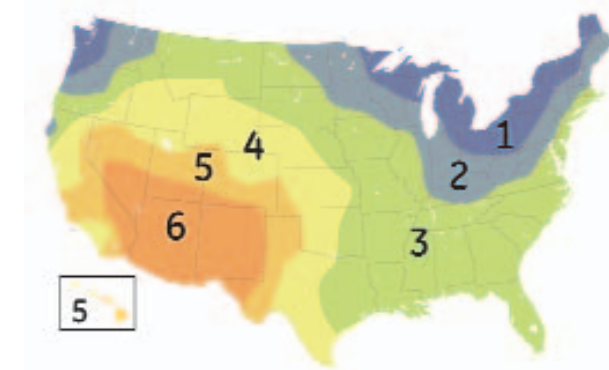

### 1 kW (DC) GE Energy Solar System

Zone	Average Monthly kWh (AC) Production Range	Zone	Average Monthly kWh (AC) Production Range
1	80-90	4	115-125
2	90-100	5	125-135
3	105-115	6	135-145

Approximate Required Roof Space [ft <sup>2</sup> ]	100
--	-----

### Typical Operational Specifications

Nominal Operating Cell Temperature (NOCT)	45°C * (Conditions: Irradiance = 800 W/m <sup>2</sup> ; ambient temperature = 20°C; wind speed = 1 m/s)
Weight (Wind) Bearing Potential	50 lbs/ft <sup>2</sup> [125 mph equivalent] (2400 N/m <sup>2</sup> [200 kph equivalent])
Hailstone Impact Resistance	1" @ 50 mph [25.4 mm @ 80.5 kph]
Module Weight	18 lbs. [8.2 kg]
Module Dimensions	17.6 x 59.3 x 2.1 in. [446 x 1507 x 52 mm]

\*NOCT is measured under industry-standard open rack conditions.  
NOCT for a tile roof mounting is installation-dependent with a typical value of 56°C.

CLASSIFIED



Timely, professional, conscientious, well-educated and well presented to us and to our customers. The GE team brings great products and great service to every project we have worked on. GE has exceeded our expectations in every realm.

Bill Pisetsky,

Vice President of Sales and Marketing  
Shea Homes of Southern California



## PHYSICAL CHARACTERISTICS

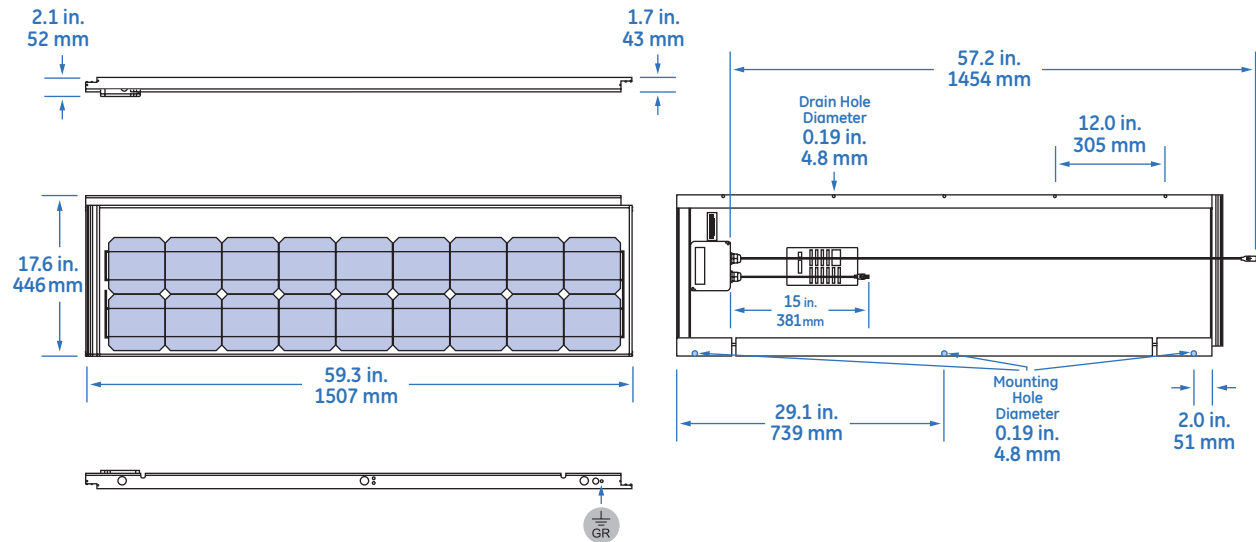

### Physical Design Properties

Weight	18.0 lb [8.2 kg]
Weight (Wind) Bearing Potential	50 lbs/ft <sup>2</sup> [125 mph equivalent]
Hailstone Impact Resistance	1" @ 50 mph [25 mm @ 80 kph]

## ELECTRICAL PERFORMANCE

### Typical I-V Curve for GEPV-055-G Module

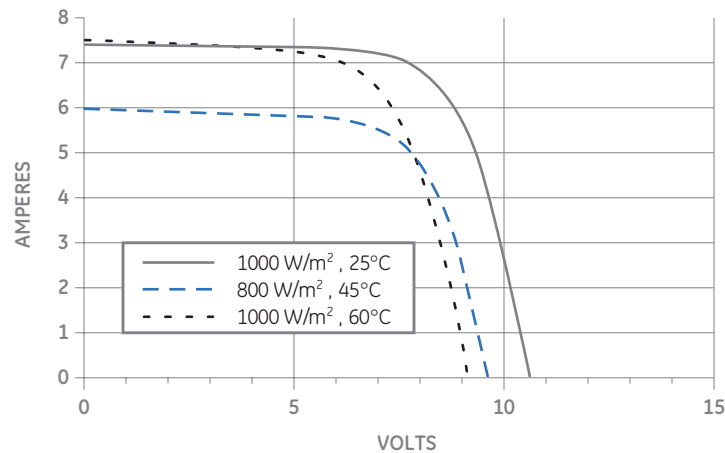

### Typical Performance Characteristics

Peak Power (Wp)	Watts	55
Max. Power Voltage (Vmp)	Volts	8.4
Max. Power Current (Imp)	Amps	6.6
Open Circuit Voltage (Voc)	Volts	10.4
Short Circuit Current (Isc)	Amps	7.5
Short Circuit Temp. Coefficient	mA/°C	+3
Open Circuit Voltage Coefficient	V/°C	-0.04
Max. Power Temp. Coefficient	%/°C	-0.5
Max. Series Fuse	Amps	18
Normal Operating Cell Temperature [NOCT]	deg. C	45

I-V parameters are rated at Standard Test Conditions (Irradiance of 1000 W/m<sup>2</sup>, AM 1.5G, cell temperature 25°C). As with all single-crystal PV Modules, during the stabilization process that occurs during the first few days in service, module power may decrease approximately 3% from typical maximum power due to a phenomenon known as Light Induced Degradation (LID). All measurements are guaranteed at the laminate leads. NOCT is defined as 800 W/m<sup>2</sup>, 20 deg. C ambient, and 1 m/s windspeed.

The GEPV-055 Module meets the following requirements:



GE Energy  
231 Lake Drive  
Newark, DE 19702  
866-750-3150

[gepower.com/solar](http://gepower.com/solar)