

GE
Energy

Energy. It's in our nature.

Cogeneration for your greenhouse
with the option of CO₂ fertilization.



GE imagination at work

greenhouse solutions with gas engines make plants grow faster

Heat, light and carbon dioxide (CO₂) promote plant growth. Plants grow by converting CO₂ to carbon through photosynthesis. Air generally contains approximately 350 ppm CO₂. Optimal CO₂ levels depend on the type of plant and generally lie above 700 ppm. With increased artificial lighting, as present in greenhouses, plants absorb even more CO₂. If the greenhouse atmosphere is enriched with CO₂, the temperature kept on a constant level and sufficient lighting provided, plant growth and consequently the harvest yield can be increased significantly.

the Jenbacher concept

The energy created by gas engine cogeneration systems in greenhouses can be used in various ways. The electricity can provide the power for the artificial lighting and/or be fed into the public grid. The heat efficiently meets the greenhouse's requirements. In addition, the CO₂ of the engine exhaust gas serves as a fertilizer for the plants.

When burning natural gas in gas engines, approximately 0.2 kg of CO₂ is produced per kWh of energy input. This CO₂ is present in the exhaust of gas engines in a concentration of approximately 5 to 6% by volume.

After the purification of the exhaust gas with special catalytic converters (SCR and oxidation catalytic converters), the exhaust gas is cooled down by a heat exchanger to approximately 55°C and supplied to the greenhouse for CO₂ enrichment. A measurement device that constantly measures the exhaust gas levels ensures maximum safety for the vegetation.

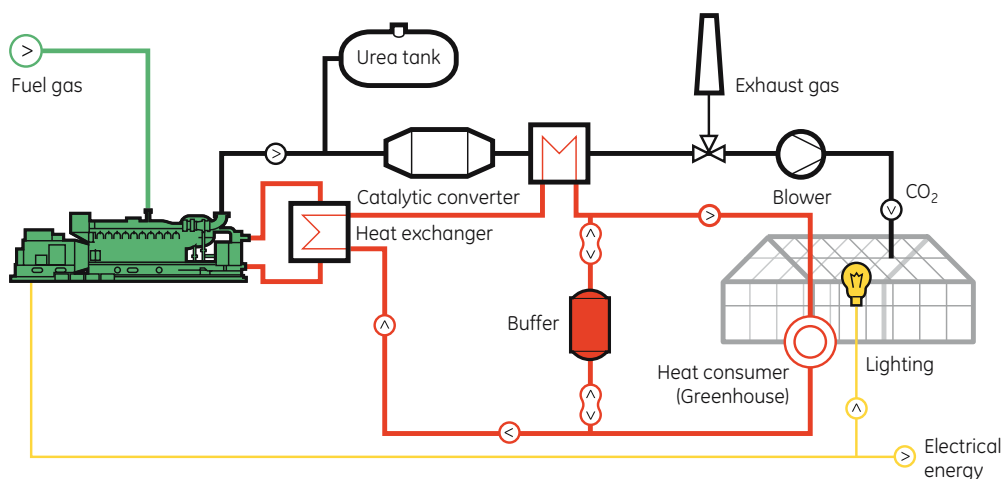

advantages of Jenbacher CHP systems in greenhouses

- Excellent overall efficiency levels of up to 95%, therefore high contribution to resource conservation
- Time-independent supply of CO₂ and heat through heat storage
- Additional flexibility through the option of supplying electricity into the public grid
- Minimum emissions through the patented LEANOX® lean mixture combustion
- Improved reliability through the additionally integratable light controls using DIA.NE® XT
- Maximum operational safety and availability through the control of the whole system via the patented engine management system, DIA.NE® XT
- Small footprint due to compact design
- Excellent CO₂ quality

key figures

- Efficient operation is possible with approximately 1 hectare (ha = 2.47 acres) or larger greenhouse areas
- CO₂ fertilization is suitable for nearly all plant types
- CO₂ fertilization with simultaneous heat supply: dimensioning for 0.5 MWel/ha
- CO₂ fertilization with simultaneous heat supply and illumination: dimensioning for 0.35 MWel/ha
- Illumination suitable for vegetables (e.g., tomatoes or peppers) and for flowers (e.g., chrysanthemums or roses)
- The decisive factors for economical plant operation are the high electrical efficiency, combined with the usage of heat and CO₂ fertilization

our competence

We have been working with the Dutch horticulturalists who pioneered CO₂ fertilization in greenhouses. Because of the experience gathered there, we have based our worldwide Center of Excellence for the application in greenhouses in our Dutch office. This new application for cogeneration plants continues to gain worldwide acceptance. Currently more than 400 Jenbacher cogeneration units with CO₂ fertilization have been supplied. Their total electrical output is about 900 MW.



GE's Jenbacher gas engine division is one of the world's leading manufacturers of gas-fueled reciprocating engines, packaged generator sets and cogeneration units for power generation. It is one of the only companies in the world focusing exclusively on gas engine technology.

GE's Jenbacher gas engines range in power from 0.25 to 4 MW and run on either natural gas or a variety of other gases (e.g., biogas, landfill gas, coal mine gas, sewage gas, combustible industrial waste gases).

A broad range of commercial, industrial, and municipal customers use Jenbacher products for on-site generation of power, heat, and cooling. Patented combustion systems, engine controls, and monitoring enable its power generation plants to meet stringent emission standards, while offering high levels of efficiency, durability, and reliability.

GE's Jenbacher product team has its headquarters, production facilities, and 1,300 of its more than 1,700 worldwide employees in Jenbach, Austria.



GEA-13721A

for more information on Jenbacher gas engines

Austria (Headquarters)

Achenseestraße 1-3
6200 Jenbach
T +43 5244 600-0
F +43 5244 600-527
jenbacher.info@ge.com
www.gejenbacher.com

Bulgaria

36, Dragan Tsankov Blvd.
1040 Sofia
T +359 2 971 4390
F +359 2 971 4384
jenbacher.bulgaria@ge.com

China

8 Floor, The Lee Gardens
33 Hysan Avenue Causeway Bay
Hong Kong
T +852 2100 6976
F +852 2100 6630
jenbacher.asiapacific@ge.com

18/F., Kerry Center
1 Guanghua Road, Chaoyang District
Beijing 100020
T +8610 5822 3821
F +8610 8529 6283
jenbacher.china@ge.com

Denmark

Samsøvej 10
8382 Hinnerup
T +45 86966788
F +45 86967072
jenbacher.scandinavia@ge.com

Egypt

54 Lebanon Street
El Mohandessin, Floor 13
Cairo
T + 20 2 33018000
jenbacher.egypt@ge.com

Germany

Amselstraße 28
68307 Mannheim
T +49 621 77094-0
F +49 621 77094-70
jenbacher.germany@ge.com

Hungary

Kisret út 1
2112 Veresegyház
T +36 2858 7376
F +36 2858 7491
jenbacher.hungary@ge.com

Italy

Via Crocioni, 46/H
37012 Bussolengo (VR)
T +39 045 6760211
F +39 045 6766322
jenbacher.italy@ge.com

North America

5244 North Sam Houston Pkwy E.
Houston, TX 77032
T +1 832 2955600
F +1 281 4429994
jenbacher.us@ge.com

Russia

Taganskaya Street, 17-23
Business Center Mosenka 4
109147 Moscow
T +7 495 7755885 1015
F +7 495 77558 84
jenbacher.russia@ge.com

Spain and Portugal

Avda. del Camino de lo Cortao, 34 - Nave 8
28703 San Sebastián de los Reyes (Madrid)
T +34 916586800
F +34 916522616
jenbacher.iberica@ge.com

The Netherlands

Kelvinring 58
2952 BG Alblasterdam
T +31 88 0019700
F +31 88 0019701
jenbacher.netherlands@ge.com

