

## Specifications and Ordering Information

# 31000, 32000 Proximity Probe Housings

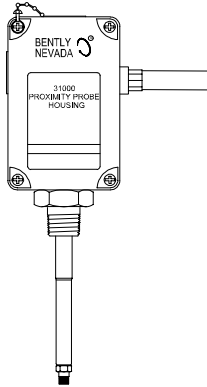

## Description

Bently Nevada's 31000/32000 Proximity Probe Housing Assemblies are recommended when mounting proximity probes through the machine case and are typically used for radially mounted transducers, whether vibration or Keyphasor® measurements.

### Notes:

1. When using these housings to measure radial vibration, ensure that the machine casing is affixed to the bearing in order to get an accurate relative vibration signal.
2. When measuring shaft axial position with dual proximity probes, use housing 21022 instead. Consult specifications and ordering information (p/n 141601-01).

Use of a proximity probe housing allows external access to the proximity probe and its extension cable, permitting gap adjustment or probe replacement without disassembly of the machine. The 31000/32000 Proximity Probe Housing Assembly is made of polyphenylene sulfide (PPS), an advanced, high-strength, thermoplastic with excellent corrosion resistance. Other elements of the housing assembly are made of corrosion-resistant stainless steel. The housing can be ordered with installed 3300 XL Proximity Probes and a variety of conduit fittings.

The 31000/32000 Proximity Probe Housing Assembly is fully compliant with the American Petroleum Institute's (API) 670 Standard for externally mounted proximity probe housings.

When installed in conjunction with an approved transducer system and appropriate I.S. barriers, the 31000/32000 Proximity Probe Housing Assembly can be used in intrinsically safe hazardous area applications.

**Note:** The 31000/32000 Housing is intended to provide mechanical and environmental protection only, and is **not** an explosion-proof housing. When an explosion proof proximity probe housing assembly is required, use housing CA21000 or CA24701. Consult specifications and ordering information (p/n 141600-01).

---

## Specifications

### Mechanical

*Protection Ratings:* Type 4X rating certified by Canadian Standards Association (CSA). IP66 rating verified by SC115582-1 (e) 106. CENELEC standard EN50014 rating for electrostatic dissipation of a plastic material located in a hazardous area.

*Housing Material:* Glass-reinforced Polyphenylene Sulfide (PPS) thermoplastic containing conductive fibers.

<i>Sleeve Material and Retaining Chain:</i>	AISI 304 stainless steel
<i>Outer Sleeve and Exterior Screws:</i>	AISI 303 stainless steel
<i>O-Ring Material:</i>	Neoprene®
<i>Recommended Torque (retaining nut):</i>	29.4 N·m (260 in·lb)
<i>Housing Strength (typical):</i>	Outer sleeve was mounted on a test stand with its axis parallel to horizontal and the housing mounted on the outer sleeve through an end hole. The housing supported 912 N (205 lb) placed approximately 38 mm (1.5 inches) from the unsupported end with the cover fastened in place and grounding liner installed.
<i>Housing Impact Strength:</i>	Certified by BASEEFA to withstand two separate 4 Joule (3.0 ft·lb) impacts at -39°C (-38°F) and at 115 °C (239°F). Samples of the housing and cover were verified by CSA to withstand a 7 Joule (5.2 ft·lb) impact at ambient room temperature.
<i>Weight:</i>	1.2 kg (2.6 lb) typical.

**Environmental Limits**

*Temperature Rating:* -34°C to +105°C (-29°F to +221°F)

**Hot Water and Steam Exposure Effects:**

(Specification not guaranteed) Brief periods (up to one week) of contact with hot water (95°C [203°F]) and/or condensing steam should not significantly affect the strength of the plastic housing. Contact with these beyond this length of time may eventually cause the strength of the plastic housing to permanently decrease during the first 6 to 8 weeks of exposure, and then level at approximately half of its initial value. Tests of actual housing performance after contact with hot water and condensing steam have not been conducted.

**Probe Pressure**

The 31000/32000 Proximity Probe Housing Assembly is designed to seal differential pressure between the probe tip and the housing main body when used with a 3300 XL 8 mm probe. The sealing material internal to the probe case consists of a Viton® O-ring; the O-ring between the sleeve and the housing is a Neoprene® O-ring. The plastic housing is certified to seal against hose-directed water according to NEMA 4X and IP66 standards but is not designed to resist internal or external pressure. Probes are not pressure tested prior to shipment. Contact our custom design department if you require a test of the pressure seal for your application.

**Note:** It is the responsibility of the customer or user to ensure that all liquids and gases are contained and safely controlled should leakage occur from a Proximity Probe Housing Assembly. Solutions with high or low pH values may erode the tip assembly of the probe, causing media leakage into surrounding areas. Bently Nevada Corporation will not be held responsible for any damages resulting from leaking Proximity Probe Housing Assemblies. In addition, Proximity Probe Housing Assemblies and 3300 XL 8 mm proximity probes will not be replaced under the service plan due to probe leakage.

Probe Cable Length	Maximum C plus D
0.5 metre	394 mm (15.5 in)
1.0 metre	760 mm (30.0 in)
<b>Table 1:</b> Maximum "C" Option plus "D" Option for different "B" Options (probe cable length)	

Probe Cable Length	Maximum C plus D with Visible P/N and S/N Label
0.5 metre	64 mm (2.5 in)
1.0 metre	483 mm (19.0 in)
<b>Table 2:</b> Maximum "C" Option plus "D" Option for different "B" Options (probe cable length) where P/N and S/N Label on Probe Cable is visible outside of probe sleeve	

## Ordering Information

**Note:** Conduit fittings are necessary when hardline conduit or metal tubing is brought into the housing. Flexible conduit should be ordered with integral 3/4-14 NPT fittings and do not require additional conduit fittings with the housing. If using flexible conduit, order the "E" = 00 option.

### 31000-AXX-BXX-CXX-DXXX-EXX-FXX

**Note:** To order housing only, use -00 for all Options.

#### Option Descriptions

- A: Probe Option, With Connector**
- 0 0** Probe not required (Note: Option B must also be -00).
  - 1 6** 3300 XL 8 mm probe
  - 2 6** 3300 XL NSv™ probe
  - 2 7** 3300 XL NSv™ probe, multiple approvals
  - 2 8** 3300 XL 8 mm probe, multiple approvals
  - 2 9** 3300 XL 8mm probe, with connector protector
  - 3 0** 3300 XL 8mm probe, with connector protector, multiple approvals
  - 3 1** 3300 XL NSv™ probe, with connector protector
  - 3 2** 3300 XL NSv™ probe, with connector protector, multiple approvals
  - 3 3** 3300 XL 11mm probe
  - 3 4** 3300 XL 11mm probe, multiple approvals
  - 3 5** 3300 XL 11mm probe, with connector protector
  - 3 6** 3300 XL 11mm probe, with connector protector, multiple approvals

- B: Probe Cable Length Option (See Table 1)**
- 0 0** Probe cable not required (Note: Option A must also be -00).
  - 0 5** 0.5 metre (20 in)
  - 1 0** 1.0 metre (39 in)

- C: Standoff Adapter Option ("C" Dimension)**
- Order in increments of 0.5 in (13 mm).  
**Minimum length:** 1.5 in (38 mm).  
**Maximum length:** 7.5 in (191 mm).  
**Example:**  
**0 0** = No standoff adapter.  
**1 5** = 1.5 in (38 mm).

- D: Probe Penetration Option ("D" Dimension)**
- Note:** "C" plus "D" dimensions greater than 12 in (305 mm) require additional sleeve support near the probe to prevent resonance from occurring. Sleeve adjustment range of Probe Penetration Option "D" is ±0.5 in (13 mm).

For penetration lengths between 1.0 and 2.0 inches, counter bore may be required in machine case to reduce probe side view and/or rear view effects.

Order in increments of 0.1 in (3 mm).

**Minimum length:** 1.0 in (25 mm).  
**Maximum length:** 30 in (762 mm), see Table 1 for cable length limits.

#### Example:

**0 0 0** = No probe sleeve.

**0 3 7** = 3.7 in (94 mm).

**2 2 4** = 22.4 in (569 mm).

#### E: Fittings Option

- 0 0** No fittings; two plugs and two washers.
- 0 1** One 3/4-14 NPT fitting, two plugs.
- 0 2** Two 3/4-14 NPT fittings, one plug.
- 0 3** Two plugs, one 3/4-14 NPT fitting, one 3/4-14 NPT to 1/2-14 NPT SST reducer, and a cable seal grip with grommets for cable sizes: 1/8 to 3/16, 1/4 to 5/16, and 5/16 to 3/8-in.
- 0 6** One 3/4-14 NPT fitting one 3/4-14 NPT to 1/2-14 NPT SST reducer and two plugs.

#### F: Mounting Thread Option

- 0 0** No outer sleeve, retainer, or retaining nut
- 0 2** 3/4-14 NPT (Required if ordering Standoff Adapter Option).
- 0 5** 7/8-14 UNF 2A

**Metric Proximity Probe Housing**  
**32000-AXX-BXX-CXX-DXXX-EXX-FXX**  
**Option Descriptions**

Note: To order housing only, use -00 for all options.

- A: Probe Option, With Connector*
- 0 0** Probe not required. (Note: Option B must also be -00).
  - 1 6** 3300 XL 8 mm probe.
  - 2 6** 3300 XL NSv™ probe
  - 2 7** 3300 XL NSv™ probe, multiple approvals
  - 2 8** 3300 XL 8 mm probe, multiple approvals.
  - 2 9** 3300 XL 8mm probe, with connector protector
  - 3 0** 3300 XL 8mm probe, with connector protector, multiple approvals
  - 3 1** 3300 XL NSv™ probe, with connector protector
  - 3 2** 3300 XL NSv™ probe, with connector protector, multiple approvals
  - 3 3** 3300 XL 11mm probe
  - 3 4** 3300 XL 11mm probe, multiple approvals
  - 3 5** 3300 XL 11mm probe, with connector protector
  - 3 6** 3300 XL 11mm probe, with connector protector, multiple approvals

- B: Probe Cable Length Option*
- 0 0** Probe cable not required (Note: Option A must also be -00).
  - 0 5** 0.5 metre
  - 1 0** 1.0 metre

- C: Standoff Adapter Option ("C" Dimension)*
- Order in increments of 10 mm.  
**Minimum length:** 40 mm.  
**Maximum length:** 200 mm.  
**Example:**  
**0 0** = No standoff adapter.  
**0 4** = 40 mm.  
**2 0** = 200 mm.

- D: Probe Penetration Option ("D" Dimension)*
- Note:** "C" plus "D" dimensions greater than 305 mm (12 in) require additional sleeve support near the probe to prevent resonance from occurring. Sleeve adjustment range of Probe Penetration Option "D" is ± 13 mm (0.5 in).  
 For penetration lengths between 25 and 50 millimeters, counter bore may be required in machine case to reduce probe side view and/or rear view effects.  
 Order in increments of 1 mm.  
**Minimum length:** 25 mm.  
**Maximum length:** 760 mm,

see Table 1 for cable length limits.

**Example:**

- 0 0 0** = No probe sleeve.
- 0 5 0** = 50 mm
- 7 6 0** = 760 mm

- E: Fittings Option*
- 0 0** No fittings; two plugs and two washers.
  - 0 1** One M25 fitting, two plugs.
  - 0 2** Two M25 fittings, one plug.
  - 0 3** Two plugs, M20 fitting, and one cable seal grip with grommet for armored probe cable.
  - 0 5** One DIN PG11 fitting, two plugs.
  - 0 7** One PG21 x M20 fitting, two plugs
  - 0 8** Two PG21 x M20 fittings, one plug
- F: Mounting Thread Option*
- 0 0** No outer sleeve, retainer or retaining nut
  - 0 1** M24 X 3
  - 0 2** 3/4-14 NPT (Required if ordering Standoff Adapter Option.)

**Terminal Housing**  
**106769 - AXX**

The 106769 housing consists of a 31000-style PPS housing with two terminal mounting blocks (each terminal block has four terminals) mounted in each housing. Sixteen ring lugs are supplied loose inside the housing for connecting transducer cables. Conduit fittings are 3/4-14 NPT chrome-plated zinc fittings.

**Option Descriptions**

- A: Conduit Fitting Option*
- 0 0** No fittings
  - 0 1** One fitting
  - 0 2** Two fittings

## Accessories

<b>124200-01</b>	Operation Manual
<b>37948-01</b>	Probe Support/Oil Sleeve Recommended for sleeves with "D" dimension longer than 12 in (305 m)
<b>108883-AXXX</b>	
<b>English Probe Sleeve (spare)</b>	

*A: Probe sleeve length* This is the measured probe sleeve length. Order in increments of 0.1 in (3 mm). Note that the individual probe sleeve length **does not** include the distance from the end of the sleeve to the probe tip or the gap from the probe tip to the target material. If only the part number of the original housing is known and the sleeve cannot be measured, use the following table to determine the sleeve length:

<b>AXX Option from 31000 Proximity Probe Housing part number</b>	<b>Calculation for 108883-XXX Probe sleeve length if original part number is known</b>
Housing AXX option for 3300 XL 8 mm probe option (A: 16 or A: 28)	AXXX: = Standoff adapter option from original housing (31000 option C) + Probe penetration option from original housing (31000 option D) + 0 2 5. <b>Example:</b> original part number is 31000-16-10-15-035-03-02. AXXX: option for replacement sleeve is (015 + 035 + 025) = <b>0 7 5</b> .
Housing AXX option for 3300 NSv™ probe option (A: 26 or A: 27)	AXXX: = Standoff adapter option from original housing (31000 option C) + Probe penetration option from original housing (31000 option D) + 0 2 6. <b>Example:</b> original part number is 31000-27-10-20-035-03-02. AXXX: option for replacement sleeve is (020 + 035 + 026) = <b>0 8 1</b> .

Housing AXX option for 3300 XL 11 mm probe option (A: 33 or A: 34)	AXXX: = Standoff Adapter Option from original housing (31000 option C) + Probe penetration option from original housing (31000 option D) + 0 1 7. Example: original part number is 31000-33-10-30-113-01-02. AXXX: Option for replacement sleeve is (030 + 113 + 017) = <b>1 6 0</b> .
--	--

*Minimum Probe Sleeve Length:* 3300 XL 8 mm probes:  
3.5 in (89 mm) = **0 3 5**

3300 NSv™ probes:  
3.6 in (91 mm) = **0 3 6**

3300 XL 11 mm probes:  
2.7 in (69 mm) = **0 2 7**

*Maximum Probe Sleeve Length:* 3300 XL 0.5 metre 8 mm probe:  
18.0 in (457 mm) = **1 8 0**

3300 NSv™ 0.5 metre probe:  
18.1 in (460 mm) = **1 8 1**

3300 XL 0.5 metre 11 mm probe:  
16.0 in (406 mm) = **1 6 0**

3300 XL 1.0 metre 8mm probe:  
32.5 in (826mm) = **3 2 5**

3300 XL NSv™ 1.0 metre probe:  
32.6 in (828mm) = **3 2 6**

3300 XL 1.0 metre 11 mm probe:  
31.7 in (805 mm) = **3 1 7**

### Metric Probe Sleeve (Spare) 108882-AXXX

*A: Probe sleeve length* This is the measured probe sleeve length. Order in increments of 1 mm (0.04 in). Note that the individual probe sleeve length **does not** include the distance from the end of the sleeve to the probe tip or the gap from the probe tip to the target material. If only the part number of the original housing is known and the sleeve cannot be measured, use the following table to determine the sleeve length:

<b>AXX Option from 32000 Proximity Probe Housing part number</b>	<b>Calculation for 108882-XXX Probe sleeve length if original part number is known</b>
Housing AXX option for 3300 XL 8 mm probe option (A: 16 or A: 28)	AXXX: = Standoff Adapter Option from original housing (32000 option C) *10 + Probe penetration option from original housing (32000 option D) + 0 6 3. <b>Example:</b> original part number is 32000-16-10-08-205-03-02. AXXX: option for replacement sleeve is (080 + 205 + 063) = <b>3 4 8</b>
Housing AXX option for 3300 NSv™ probe option (A: 26 or A: 27)	AXXX: = Standoff adapter option from original housing (32000 option C) *10 + Probe penetration option from original housing (32000 option D) + 0 6 6. <b>Example:</b> original part number is 32000-27-10-10-105-03-02. AXXX: option for replacement sleeve is (100 + 105 + 066) = <b>2 7 1</b> .
Housing AXX option for 3300 XL 11mm probe option (A: 33 or A: 34)	AXXX: = Standoff adapter option from original housing (32000 option C) *10 + Probe penetration option from original housing (32000 option D) + 0 4 2. <b>Example:</b> original part number is 32000-33-10-10-105-03-02. AXXX: option for replacement sleeve is (100 + 105 + 042) = <b>2 4 7</b> .

**Minimum Probe Sleeve Length:**

3300 XL 8 mm probes:  
88 mm (3.5 in) = **0 8 8**

3300 NSv™ probes:  
91 mm (3.6 in) = **0 9 1**

3300 XL 11 mm probes:  
67 mm (2.6 in) = **0 6 7**

**Maximum Probe Sleeve Length:**

3300 XL 0.5 metre 8 mm probe:  
457 mm (18.0 in) = **4 5 7**

3300 NSv™ 0.5 metre probe:  
460 mm (18.1 in) = **4 6 0**

3300 XL 0.5 metre 11 mm probe:  
436 mm (17.2 in) = **4 3 6**

3300 XL 1.0 metre 8 mm probe:

823 mm (32.4 in) = **8 2 3**

3300 NSv™ 1.0 metre probe:  
826 mm (32.5 in) = **8 2 6**

3300 XL 1.0 metre 11 mm probe:  
802 mm (31.6 in) = **8 0 2**

**English Standoff Adapter (Spare) 109319-AXXX**

A: *English standoff Adapter length*

Hex = 1 3/8 in; threads = 3/4-14 NPT

Order in increments of 0.5 in (13 mm).

**Minimum length:** 1.5 in (38 mm).  
**Maximum length:** 7.5 in (191 mm).  
**Example:** **0 4 5** = 4.5 in (114 mm).

**Metric Standoff Adapter (Spare) 109318-XX**

A: *Metric Standoff Adapter length*

Wrench flats = 35 mm; threads = 3/4-14 NPT.  
Order in increments of 10 mm.

**Minimum length:** 40 mm.  
**Maximum length:** 200 mm.  
**Example:** **1 2** = 120 mm.

**Note:** For desired probe penetration lengths of less than 25 mm (1.0 in), order a separate Individual Standoff Adapter. The effective probe penetration length will then be reduced by the length of the Individual Standoff Adapter, plus an additional 13 mm (0.5 in) due to the NPT thread engagement.

**Example:** The customer desires a probe penetration length of 13 mm (0.5 in). To do this, they order a 31000 housing with DXXX (probe penetration) option of 0 3 0 [76 mm (3.0 in)] and a **separate** individual standoff adapter that is 51 mm (2.0 in) in length (part number **109319-020**). The standoff adapter would cover 38 mm (2.0 in) of the probe sleeve, plus an additional 13 mm (0.5 in). Therefore, the effective probe penetration length would drop to 13 mm (0.5 in).

**Note:** Signal affects due to probe side view and/or rear view of metal components are likely when effective penetration lengths of less than 1.0 inch are used.

**Spare 3300 XL 8 mm Reverse Mount Probe, 3/8-24 UNF threads 330105-02-12-CXX-DXX-EXX**

**Spare 3300 XL 8 mm Reverse Mount Probe, M10 X 1 threads 330106-05-30-CXX-DXX-EXX Option Descriptions**

C: <i>Total Length Option</i>	<b>0 5</b>	0.5 metre (1.6 feet)
	<b>1 0</b>	1.0 metre (3.3 feet)
	<b>1 5</b>	1.5 metre (4.9 feet)
	<b>2 0</b>	2.0 metres (6.6 feet)
	<b>5 0</b>	5.0 metres (16.4 feet)
	<b>9 0</b>	9.0 metres (29.5 feet)

<i>D: Connector Option</i>	<b>0 0</b>	Connector not installed		
	<b>0 2</b>	Miniature ClickLoc™ coaxial connector	<b>104288-02</b>	Metric Blanking Plug.
				<b>Note:</b> Plugs fill extra holes in plastic housing where needed.
<i>E: Agency Approval Option</i>	<b>0 0</b>	Not required		
	<b>0 5</b>	Multiple Approvals		
<i>Heavy Duty Conduit and Cable Fittings</i>				
<b>Spare 3300 NSv™ Reverse Mount Probe, 3/8-24 UNF threads 330906-02-12-CXX-DXX-EXX</b>			<b>03813103</b>	Chrome-plated Zinc Conduit Fitting, 3/4-14 NPT
<b>Spare 3300 NSv™ Reverse Mount Probe, M10 X 1 threads 330907-05-30-CXX-DXX-EXX</b>			<b>03818100</b>	AISI 316 Stainless Steel Conduit Fitting, 3/4-14 NPT
<b>Option Descriptions</b>			<b>03818101</b>	AISI 316 Stainless Steel Conduit Fitting, PG21 x M25
<i>C: Total Length Option</i>	<b>0 5</b>	0.5 metre (1.6 feet)		
	<b>1 0</b>	1.0 metre (3.3 feet)		
	<b>5 0</b>	5.0 metres (16.4 feet)		
	<b>9 0</b>	9.0 metres (29.5 feet)	<b>03818102</b>	AISI 316 Stainless Steel Conduit Fitting, PG21 x M20
<i>D: Connector Option</i>	<b>0 0</b>	Connector not installed	<b>03818103</b>	AISI 316 Stainless Steel Conduit Fitting, PG21 x PG11
	<b>0 2</b>	Miniature ClickLoc™ coaxial connector	<b>03818104</b>	AISI 303 Stainless Steel Cable Gland, PG11
<i>E: Agency Approval Option</i>	<b>0 0</b>	Not required		
	<b>0 5</b>	Multiple Approvals	<b>03818105</b>	AISI 316 Stainless Steel Cable Gland, M20
<i>Sleeve and Blanking Plugs</i>				
<b>104968-01</b>		English Sleeve Plug, threaded, 303 stainless steel.	<b>03818111</b>	Nickel-plated Brass Conduit Fitting, PG21 x M20
<b>104968-02</b>		Metric Sleeve Plug, threaded, 303 stainless steel.	<b>26650-01</b>	AISI 303 Stainless Steel Reducer, 3/4-14 NPT to 1/2-14 NPT
		<b>Note:</b> Plugs fill opening when sleeve is removed from machine case.		
<b>104288-01</b>		English Blanking Plug		

© 2002 Bently Nevada, LLC

® used in this document are registered marks of Bently Nevada, LLC

# Dimensional Drawing

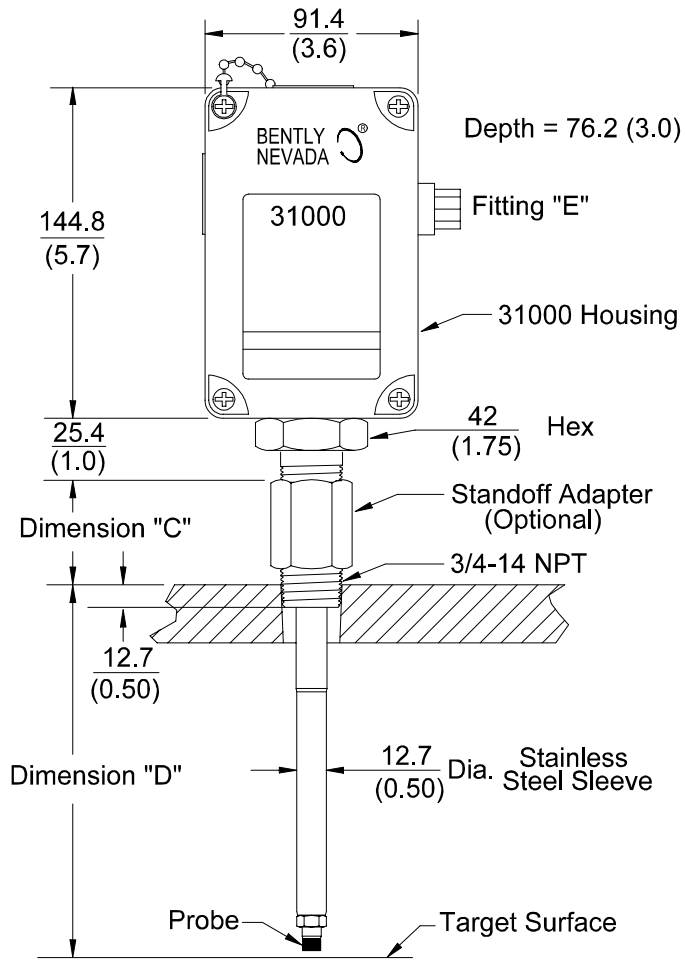

**Figure 1: Dimensions for 31000 and 32000 Proximity Probe Housings**  
Dimensions are in millimetres (inches)

All 4 holes in housing base, 1 per side, will accept sleeve or conduit fittings and cable glands.  
 Fittings are supplied with housing depending on English, metric or DIN type.  
 Hole plugs are provided to seal unused holes.

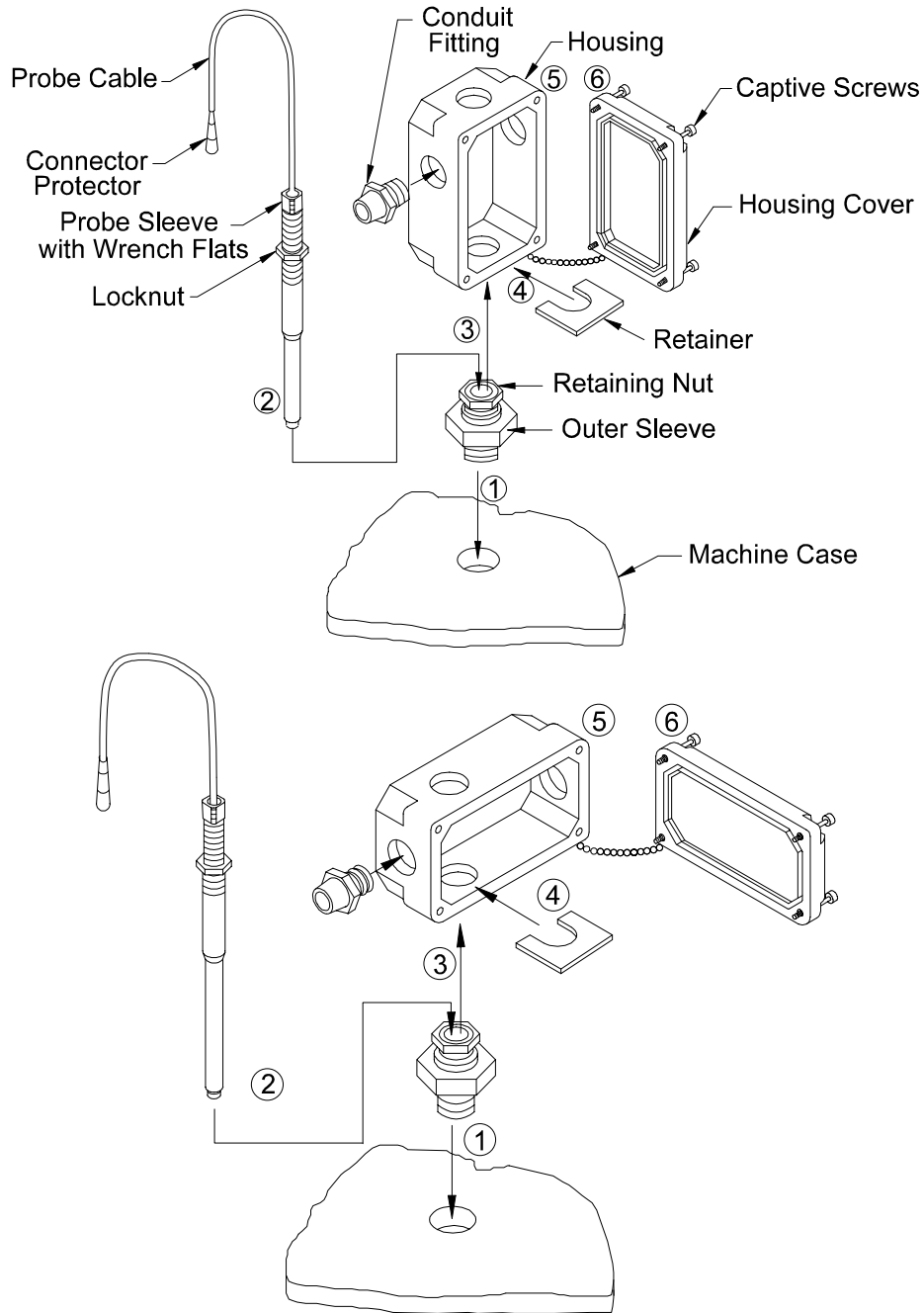

### Installation Procedures

1. Install outer sleeve into machine case.
2. Insert probe sleeve and adjust probe gap.
3. Disconnect probe cable and fit housing over outer sleeve.
4. Slide retainer under retaining nut. Tighten nut.
5. Re-connect probe cable and Connector Protector.
6. Place housing cover on housing and tighten captive screws.
7. If hole plugs are used, tighten hole plug nuts to 0.5 N-m (5 in-lbs).

Figure 2: Vertical profile and horizontal profile views of the Proximity Probe Housings