



---

## Specifications

---

### Inputs

*Compatible transducers* Bently Nevada's 200150 and 190520 Accelerometers.

*Input Sensitivity* 100 mv/g

*Maximum acceleration* 20 g peak

*Maximum differential input voltage* 4 volts peak to peak

---

### Power

*AC/HDC Power Version* AC Voltage: 85 to 264 Vac  
DC Voltage: 110 to 370 Vdc  
Current Draw: 60 mA. typ.  
120 mA max.  
Frequency: 47 Hz to 440 Hz, or DC.  
Inrush: 20A typ. @ Vin=100Vac  
40A typ. @ Vin=200Vac

*+24 Vdc Power Version* Voltage: 18 to 36 Vdc  
Current Draw: 300 mA max.

---

### Signal Conditioning

Monitor Full-scale: (*Below 614Hz*)

*English Units:* 2.0 in/s zero-to-peak

*Metric Units:* 50.8 mm/s zero-to-peak

Note: Full scale is limited by maximum input above 614 Hz. The maximum input is 2 volts peak, or 20 g peak. 20 g at 614 Hz is equivalent to 2 inch per second (the full scale range of the monitor). For frequencies above 614 Hz, Full scale is equal to (1228/frequency).

Frequency Response:

*High pass corner frequency* -3 dB corner @ 8 Hz  
less than 1% error due to high pass corner above 30 Hz

*Low pass corner* Greater than 4 kHz  
less than 1% error due to low pass corner below 4kHz

---

### Accuracy

*Liquid Crystal Display and Buffered output.*

*30 Hz – 4 kHz:* ±3% of full scale, Maximum

*8 Hz – 30 Hz* -30% , + 3% of full scale

*Trendmaster Output.*

*30 Hz – 4 kHz:* ±5% of full scale, Maximum

*8 Hz – 30 Hz* -30% , + 5% of full scale

---

### Outputs

*Buffered Transducer Output*

*Output Sensitivity:* 19.7 mV/mm/s (500 mV/in/s)

*Output Impedance:* 500 Ω

*Full-scale Range:* 50.8 mm/s (2 in/s) zero-to-peak

*Trendmaster® 2000 Interface*

*Full-scale Range:* 50.8 mm/s (2 in/s)

*Overrange:* 63.5 mm/s (2.5 in/s)

*Frequency Response:* 10 Hz to 1 kHz

*Galvanic Isolation:* Optical @ 1000 Vac or 707 Vdc

---

### Relays

*Type* Single-pole, double-throw.

*Contact Ratings*

*Switched Power:* 180 watts, 1800 VA Maximum

*Maximum Voltage and Current* 300 Vac at 6 A  
28 Vdc at 6 A

*Dielectric Strength (at sea level):* Contact to Contact: 750 Vrms  
Contact to Coil: 1500 Vrms

*Life Expectancy*

*Electrical:* 180,000 operations at 6 A, 120 Vac

---

## Displays

### Liquid Crystal Display

*Size:* 50.8 mm wide x 22.8 mm high  
(2.0 inches wide x 0.9 inches high)

*Full-scale:* 50.8 mm/s (1.999 in/s)

*Refresh Rate:* 0.8 s

### LED Indicators

*OK:* One constant ON green LED indicates OK condition of monitor, transducers, and field wiring. Constant OFF indicates NOT OK condition. OK LED flashing at 2 Hz indicates monitor has been NOT OK, but is now OK.

*Alert:* One yellow LED indicates an Alert condition. Flashing at 2 Hz indicates an Alert condition has occurred and gone away. (Only occurs when the Alert relay is configured as nonlatching.)

*Danger:* One of the two red LEDs indicates a Danger condition. Flashing at 2 Hz indicates a Danger condition has occurred and gone away. (Only occurs when the Danger relay is configured as nonlatching.)

*BYPASS:* The other red LED indicates the monitor is in BYPASS mode.

---

## Controls

*Display Mode Switch:* Three positions: Normal, Alert Setpoint, and Danger Setpoint. Controls what is shown on the LCD display.

*Relay Mode Switch:* Two positions; controls whether monitor is in normal or BYPASS mode.

*Reset Button:* Push to reset latching relays and flashing LEDs.

*Configuration Switch* Used to set Alert and Danger Time Delay, Alert relay drive conditions, display units, and to initiate a monitor self-test.

---

## Environmental Limits

*Operating Temperature:* -20°C to +70°C (-4°F to +158°F)

*Storage Temperature:* -30°C to +90°C (-22°F to +194°F)

*Relative Humidity:* To 95%, noncondensing

---

## Hazardous Area Approvals

*CSA/NRTL/C:* Class1, Division 2, Groups A, B, C, D T4 @ Ta=70 °C

---

## Physical

### Dimensions

*Length:* 132 mm (5.20 inches)

*Width:* 132 mm (5.20 inches)

*Depth:* 71.1 mm (2.80 inches)

*Weight* 400 grams (0.85 lbs).

---

## Ordering Information

### 1900/25-AXX

#### Option Descriptions

*A: Power Supply*     **0 1** 85 - 264 Vac, 110 – 370 DC  
*Option*                 **0 3** +24 Vdc

---

## Field-programmable Options

These options are either field-changeable or programmed via internal jumpers. **Bold text** indicates options as shipped from the factory.

*Alarm Time Delay*     **3 seconds**  
*Option:*                    5 seconds

10 seconds  
15 seconds

*Alert Relay Configuration Option:* **Alert relay**  
Alert or NOT OK relay  
NOT OK relay  
Danger relay

*Units Option:* **English**  
Metric

*Monitor Self-test Option:* **Off**  
On

*Relay Mode Option:* **Normal**  
BYPASS

*Normal Relay State Option:* **Normally de-energized**  
Normally energized

*Relay Reset Option:* **Latching**  
Nonlatching

*Trendmaster® 2000 Behavior Option:* **The Trendmaster® 2000 host computer indicates a NOT OK condition when the monitor is placed in BYPASS. Dynamic data is not available during a BYPASS condition.**

The Trendmaster® 2000 host computer indicates an OK condition when the monitor is placed in BYPASS. Dynamic data is still available during a BYPASS condition.

---

## Accessories

---

**200150 Accelerometer**  
**200150-AXX**  
See Specification and Ordering Information sheet for transducer ordering information.

**200152 Transducer Cable**  
**200152 - AXX**  
**Option Description**

*A: Cable length option in metres.* **1 5** 15 ±0.15 metre (49.2 ±0.5 feet)

**190100-01** Weatherproof enclosure for one 1900/25 Vibration Monitor. When properly installed, the weatherproof enclosure will meet NEMA 4X watertight specifications.

### *Manual*

**190125-01** 1900/25 Vibration Monitor operation and maintenance.

**Computer Interface:** The 1900/25 Vibration Monitoring System is ready to be used with Bently Nevada's cost-effective, automated data collection and diagnostic system, the Trendmaster® 2000. Contact your nearest Bently Nevada Sales Professional for further information.

Field wiring diagrams and dimensions

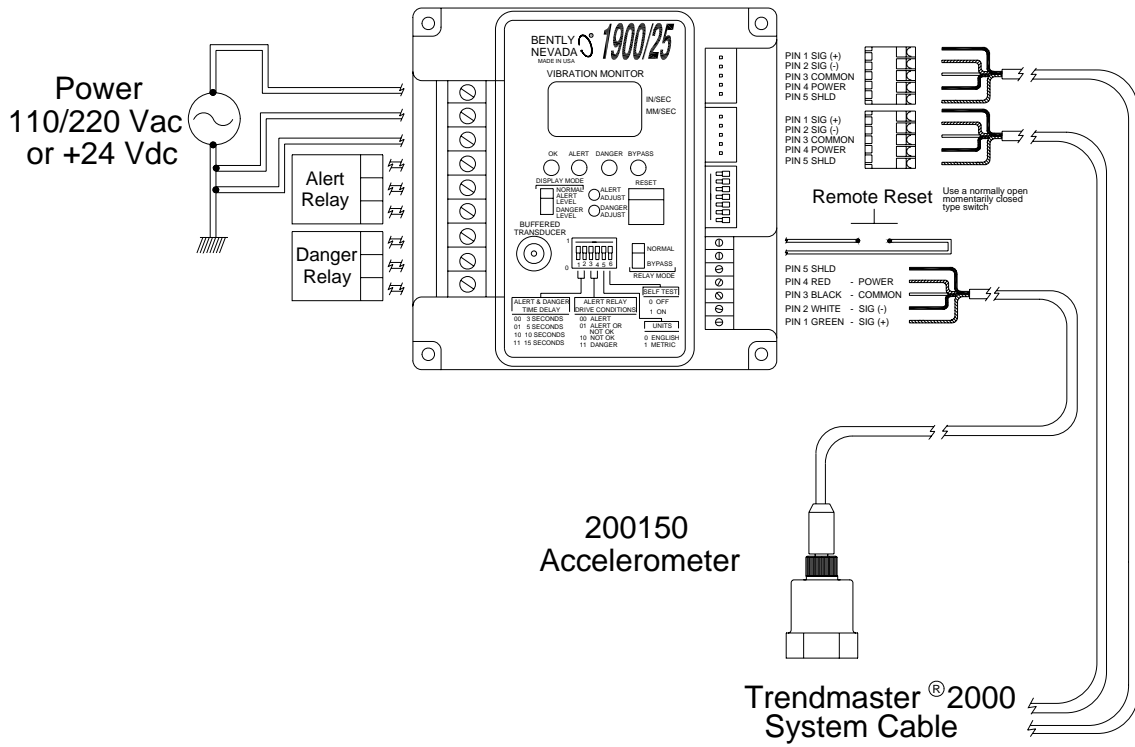

Figure 1: Typical field wiring diagram for the 1900/25 Vibration Monitoring System

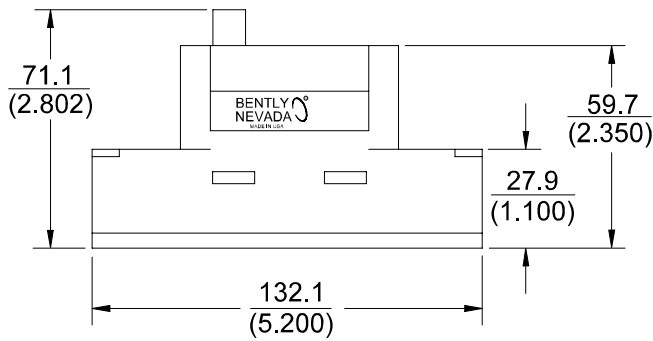
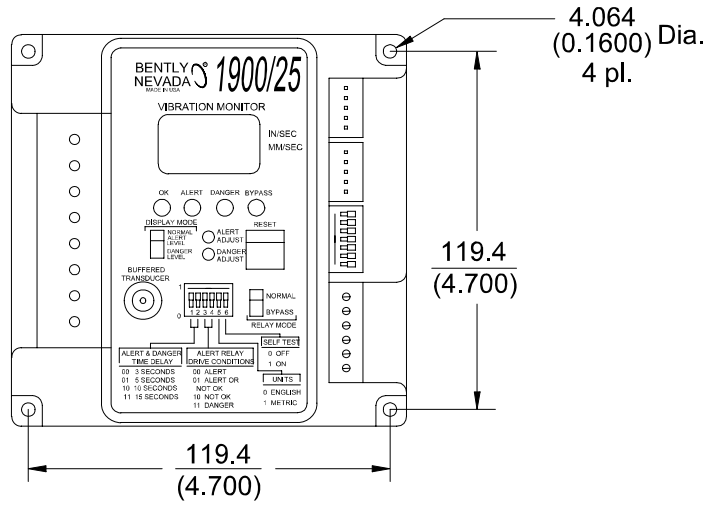

Figure 2: 1900/25 Vibration Monitor Case Dimensions Diagram  
Dimensions are in millimetres (inches)

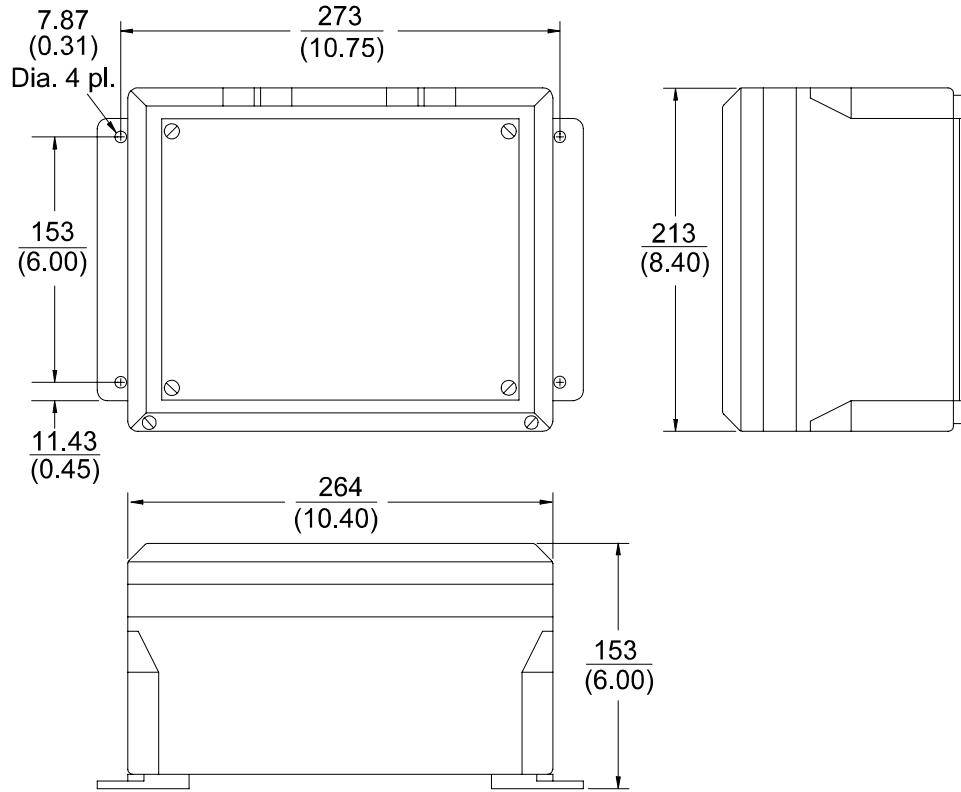

Figure 3: 1900/25 Weatherproof Enclosure Dimensions Diagram  
 Dimensions are in millimetres (inches)