

Specifications and Ordering Information 350900 High Temperature Velocity and Acceleration Sensor

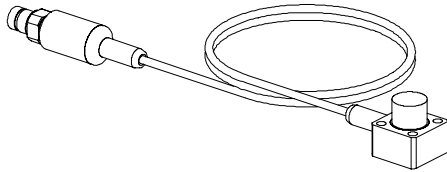

Description



The 350900 High Temperature Velocity and Acceleration Sensor (HTVAS) provides a continuous acceleration and velocity output, allowing the customer to protect their machine with an velocity signal while simultaneously capturing the acceleration signal for machinery diagnostics. It is primarily designed for use with the 3500/42M and 3500/44M monitors. When attached to the 3500/42M or 3500/44M monitors, the acceleration and velocity signals from one transducer must be used on a separate channel pair (such as channels 1 and 3) or separate monitors.

The 350900 High Temperature Velocity and Acceleration Sensor (HTVAS) separates the high-temperature sensing element from the signal conditioning electronics, with the two permanently connected via a hardline cable. This arrangement allows the sensing head to be mounted on surfaces with temperatures as high as +482 °C (+900 °F), while the signal conditioning electronics can be installed in a cooler location. By eliminating connections between the sensing head and its associated signal conditioning electronics, a significant source of potential transducer failures (connector problems) is eliminated. This achieves overall transducer system performance comparable to other case mounted vibration transducers, but permits use at significantly higher temperatures. The main features of the 350900 HTVAS are as follows:

- Velocity and acceleration output
- High temperature operation up to +482 °C (+900 °F)
- Electronics rated to +125 °C (+257 °F), survivable to +155 °C (+311 °F)

Caution

If housing measurements are being made for overall protection of the machine, thought should be given to the usefulness of the measurement for each application. Most common machine malfunctions (imbalance, misalignment, etc.) originate at the rotor and cause an increase (or at least a change) in rotor vibration. In order for any housing measurement alone to be effective for overall machine protection, a significant amount of rotor vibration must be faithfully transmitted to the bearing housing or machine casing, or more specifically, to the mounting location of the transducer.

In addition, care should be exercised in the physical installation of the transducer. Improper installation can result in a degradation of the transducer's performance, and/or the generation of signals which do not represent actual machine vibration.

Upon request, Bently Nevada can provide engineering services to determine the appropriateness of housing measurements for the machine in question and/or to provide installation assistance.



Specifications

Specifications are between +20 °C and +30 °C (+ 68 °F to + 86 °F) with machine casing vibration at 100 Hz (6000 cpm) and with a 10 kΩ load unless otherwise indicated.

Electrical

Power requirements:

Input Voltage: -18 to -30 Vdc; -18 to -28 Vdc for hazardous area approval options.

Quiescent Current: 6 mA nominal, no load.

Transverse sensitivity: Less than 5% of axial sensitivity.

Amplitude linearity: ± 1% to 4900 m/s² (500 g) peak overall acceleration.

Mounted Resonant Frequency: Greater than 15 kHz.

Maximum cable length: 305 metres (1000 ft).

Grounding: Case isolated.

Velocity Output:

Sensitivity: 3.94 mV/mm/s (100 mV/in/s) ± 5%.

Frequency Response: 18 Hz to 1 kHz (1080 cpm to 60 kcpm) ± 5% with 305 metres (1000 ft) of cable.

10 Hz to 2 kHz (600 cpm to 120 kcpm) ± 3 dB with 305 metres (1000 ft) of cable.

System Sensitivity over Extended Temperatures: Over a sensor temperature range of -54 °C to +399 °C (-65 °F to +750 °F) and with the electronics between -54 °C to +125 °C (-65 °F to +257 °F), the output remains within ± 10% of 3.94 mV/mm/s (100 mV/in/s).

Over a sensor temperature range of -54 °C to +482 °C (-65 °F to +900 °F) and with the electronics between -54 °C to +125 °C (-65 °F to +257 °F), the output remains within ± 15% of 3.94 mV/mm/s (100 mV/in/s).

Output Bias Voltage: -10.0 ± 2.0 Vdc.

Velocity range: 1270 mm/s (50 in/s).

Broadband Noise Floor (5 Hz to 2 kHz): 0.05 mm/s rms (0.002 in/s rms), max.

Acceleration Output:

Sensitivity: 1.02 mV/m/s² (10 mV/g) ± 5%.

Frequency Response: 13 Hz to 4 kHz (780 cpm to 240 kcpm) ± 5% with 305 metres (1000 ft) of cable.
5 Hz to 10 kHz (300 cpm to 600 kcpm) ± 3 dB with 305 metres (1000 ft) of cable.

System Sensitivity over Extended Temperatures: Over a sensor temperature range of -54 °C to +399 °C (-65 °F to +750 °F) and with the electronics between -54 °C to +125 °C (-65 °F to +257 °F), the output remains within ± 10% of 1.02 mV/m/s² (10 mV/g).

Over a sensor temperature range of -54 °C to +482 °C (-65 °F to +900 °F) and with the electronics between -54 °C to +125 °C (-65 °F to +257 °F), the output remains within ± 15% of 1.02 mV/m/s² (10 mV/g).

Output Bias Voltage: -10.0 ± 2.0 Vdc.

Acceleration range: 4900 m/s² (500 g).

Broadband Noise Floor (5 Hz to 10 kHz): 147 mm/s² (1.5 mg) rms, max.

Hazardous Area Classification:

Multiple approvals for hazardous areas certified by Canadian Standards Association (CSA/NRTL/C) in North America and by LCIE/CENELEC in Europe.

CSA/NRTL / C: Ex ia/Aex ia for Class I Zone 0 IIC T4 or Division 1, Groups A, B, C, D; Class II, Division 1, Groups E, F G; and Class III, when installed with an approved zener barrier or galvanic isolator per BN drawing 167923.

Ex nL/AEx nL Class I Zone 2 IIC T4 or Division 2 when installed without barriers per BN drawing 167923. T4 @ Ta = 100 °C (212 °F).

EUROPEAN: EEx ia IIC T4 for Zones 0, 1, and 2, Group IIC, EC certificate number LCIE 04 ATEX 6140 X, when installed with intrinsically safe zener barriers or galvanic isolators. T4 @ Ta = 100°C (212 °F).

EEx nL for Class I, Zone 2, Group IIC, EC certificate number LCIE 04 ATEX 6141 X.

Electromagnetic Compatibility

Electrostatic discharge: EN 61000-4-2, Criteria A.

Electrical fast transients: EN 61000-4-4, Criteria A.

Radiated Susceptibility: EN 61000-4-3, Criteria A.

Conducted Susceptibility: EN 61000-4-6, Criteria A.

Surge Capability: EN 61000-4-5, Criteria A.

Magnetic Field: EN 61000-4-8, Criteria A.

Environmental Limits

Operating and storage temperature:

Sensor: -54° C to +482° C (-65° F to +900° F).

Mineral Insulated Cable: -54° C to +482° C (-65° F to +900° F).

Electronics: -54° C to +125° C (-65° F to +257° F).

Soak Back Temperature: The electronics will survive temperature exposure of +155° C (+311° F) for four hours without failure. Electrical performance will not be met during this period.

Shock Survivability: 19,620 m/s² (2000 g) peak, maximum.

Relative humidity: 100% condensing, non-submerged. Case is hermetically sealed.

Physical

Sensor:

Dimensions: See Figure 1

Mounting: 30.2 mm (1.188 in) square mounting hole pattern, 7.2 mm (0.283 in) mounting holes (4 holes).

Mounting Surface: 32 microinch rms.

Material: 600 Inconel® steel.

Integral Cable:

Diameter: 6.35 ± 1.27 mm (0.25 ± 0.05 in)

Material: 300 Series Stainless Mineral Insulated Integral Cable with Stainless Steel Overbraid.

Bend Radius: Minimum bend radius of 51 mm (2.0 in).

Integral Electronics:

<i>Dimensions:</i>	See Figure 1
<i>Mounting:</i>	Patch panel hub mount.
<i>Material:</i>	300-series stainless steel.
<i>Connector:</i>	MIL-DTL-83723/90 - 1006N with gold-plated 300-series stainless steel.
<i>System Weight (without field wiring):</i>	0.545 kg + 0.10 kg/m cable length (1.200 lb + 0.006 lb/in cable length), typical.
<i>Mounting angle:</i>	Any orientation

Ordering Information

High Temperature Velocity and Acceleration Sensor

350900-AXXX

Option Descriptions:

<i>A: Integral Cable</i>	0 2 3	23 inches (0.58 metres)
<i>Length Option</i>	0 2 6	26 inches (0.66 metres)
	0 2 7	27 inches (0.69 metres)
	0 4 4	44 inches (1.12 metres)
	0 7 7	77 inches (1.96 metres)
	0 8 3	83 inches (2.11 metres)
	1 5 8	158 inches (4.00 metres)
	2 3 7	237 inches (6.00 metres)
	3 1 5	315 inches (8.00 metres)
	3 9 4	394 inches (10.0 metres)

350901-040 40 foot (12.2 metre) field interconnect cable.

© 2004 Bently Nevada, LLC.

® used in this document are registered marks of Bently Nevada, LLC.

Dimensional drawing

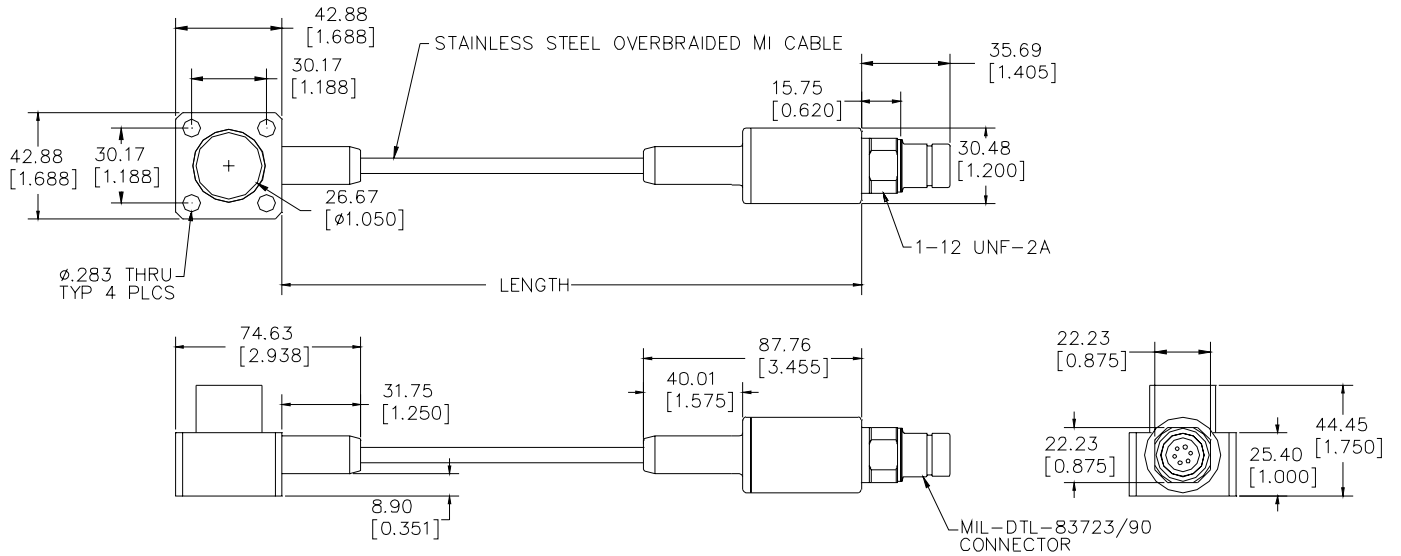

Figure 1: Transducer dimensional drawing
 Dimensions are in millimetres (inches)

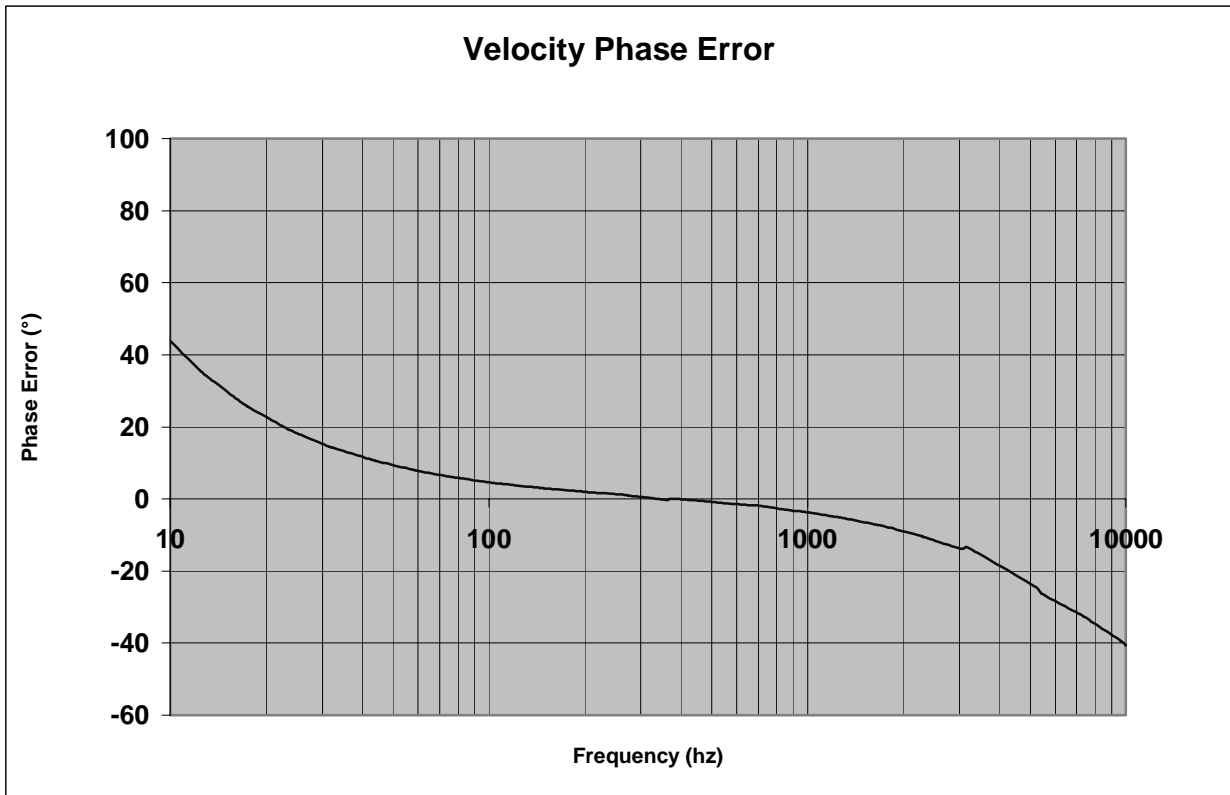
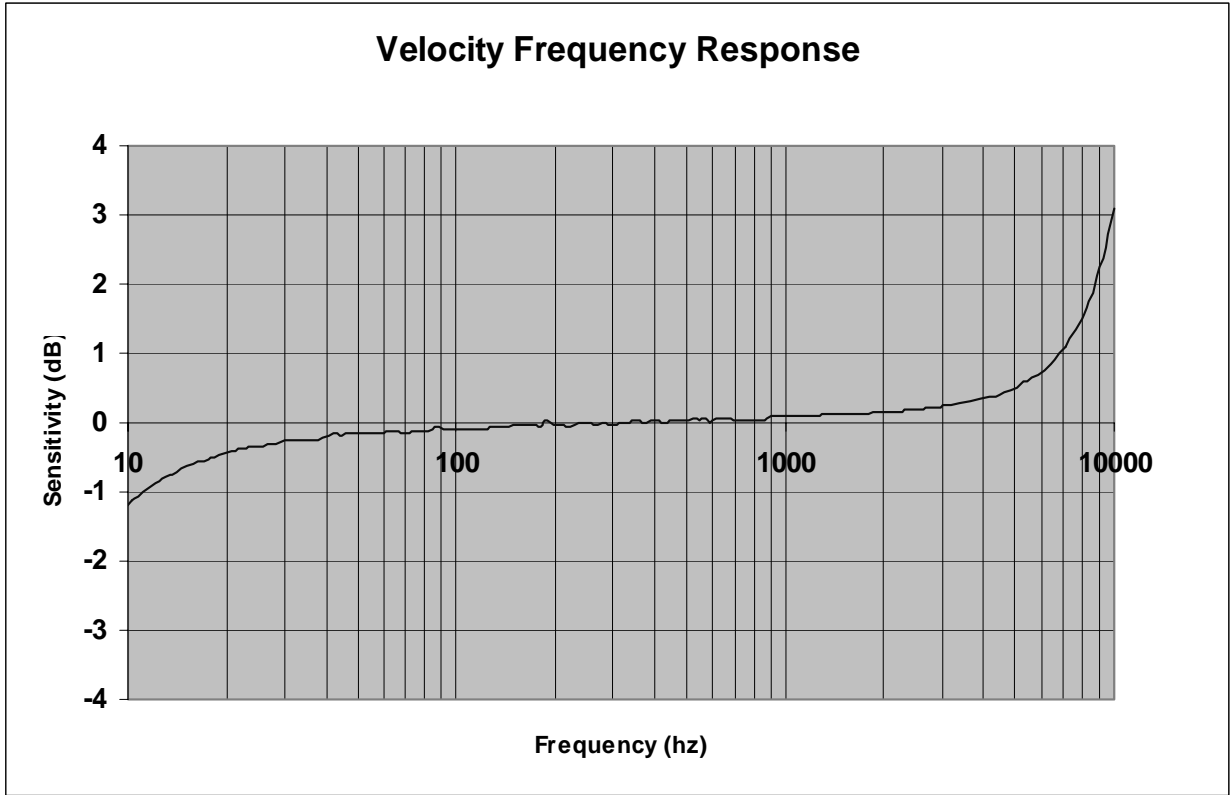

Figure 2: Velocity Amplitude and Phase Response

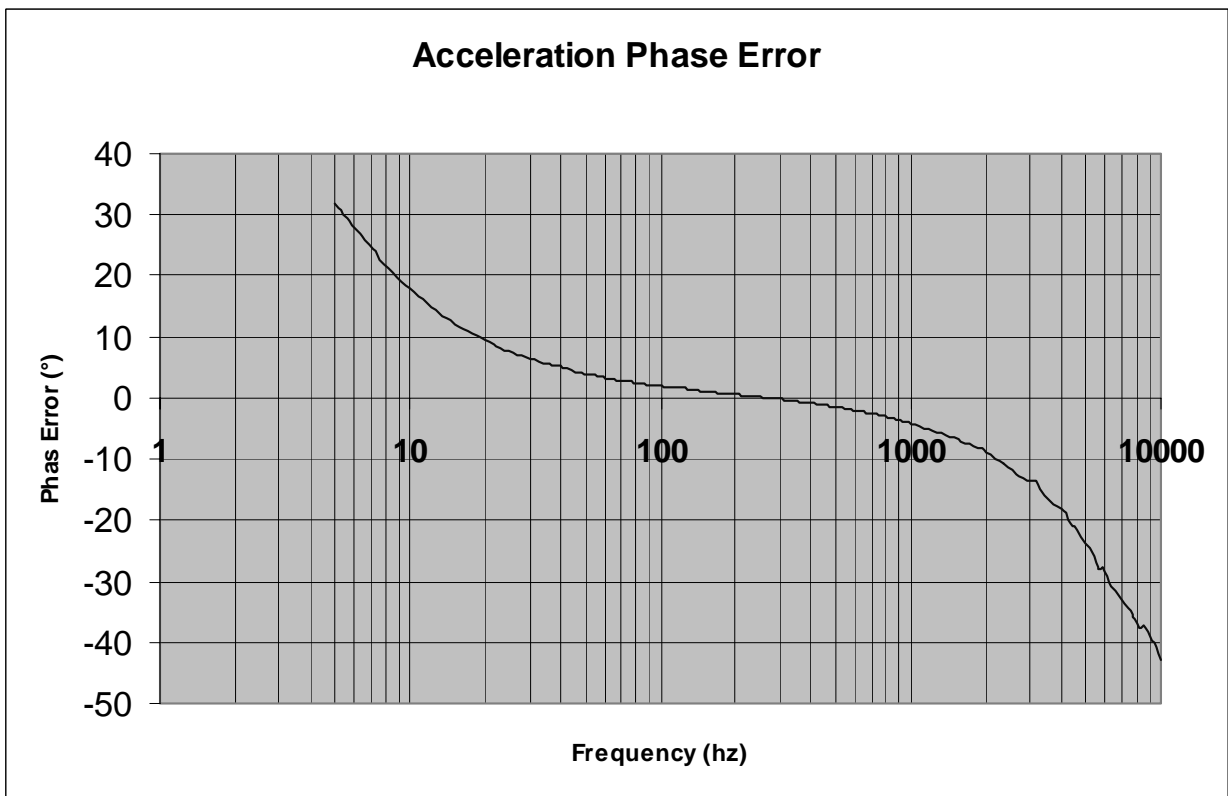
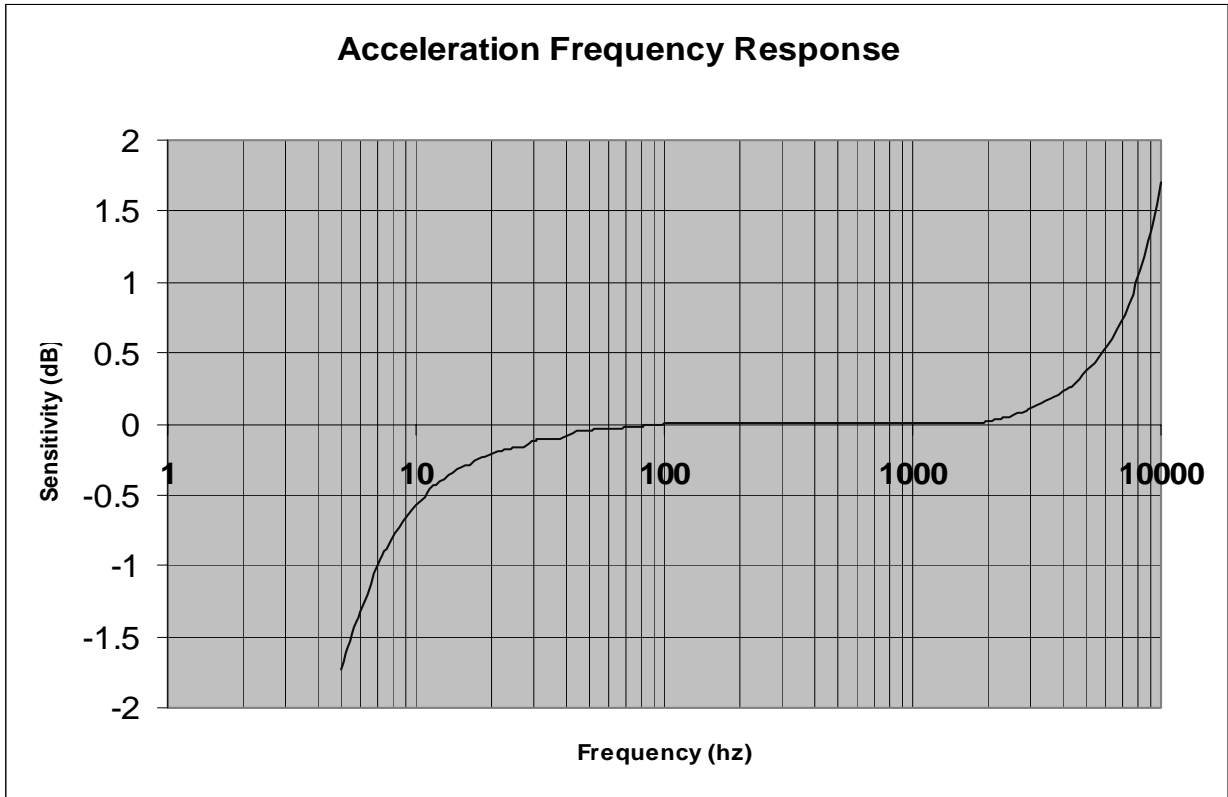

Figure 3: Acceleration Amplitude and Phase Response