

GE's GateCycle* software is one of the most powerful, flexible, and fully featured heat balance modeling applications available today.

GateCycle predicts design and off-design performance of combined-cycle power plants, conventional steam plants, cogeneration systems, combined heat-and-power plants, advanced gas turbine cycles, and many other energy systems.

It enables users to model virtually any type of energy system using a single software package. With the flexibility to incorporate user-defined equations and tables, to simulate control loops, and to vary an unrestricted number of model parameters in an optimization routine, GateCycle is the perfect tool to optimize a plant's design or to simulate the operation of an existing plant under specific conditions.

How GateCycle Works

A GateCycle model represents a specific plant or equipment configuration. In design mode, the user specifies the performance attributes required. The software then calculates ("sizes") the equipment to match this performance criteria. In off-design mode, the software works in the other direction: the user enters the "as-built" equipment data and the GateCycle application calculates the corresponding "as-built" performance. GateCycle models are extremely flexible, allowing an indefinite number of calculation cases to cover variations in design parameters as well as plant performance under 'off-design' conditions.

When the model is executed, a sequential modular algorithm solves the mass and energy balances for both the overall system as well as all individual components, and detailed reports for each are generated automatically. If equipment constraints cannot be met or the heat balance cannot be solved, an error file is generated, allowing the user to identify the source of the problem and correct the model accordingly.



Typical Benefits

- Model any plant with one program
- From pre-feasibility study to plant acceptance test with one program
- Design and off-design analyses completely integrated
- Both simple or in-depth modeling levels available
- Capability to model equipment 'as built'
- Graphical user interface, guided data entry and intuitive on-line help
- Icon-by-icon analysis

Applications

- Conceptual plant design
- Detailed design work
- Parametric studies
- Feasibility studies
- Pro-formats
- 'What-if' analysis
- Plant retrofits/re-powering
- and many others

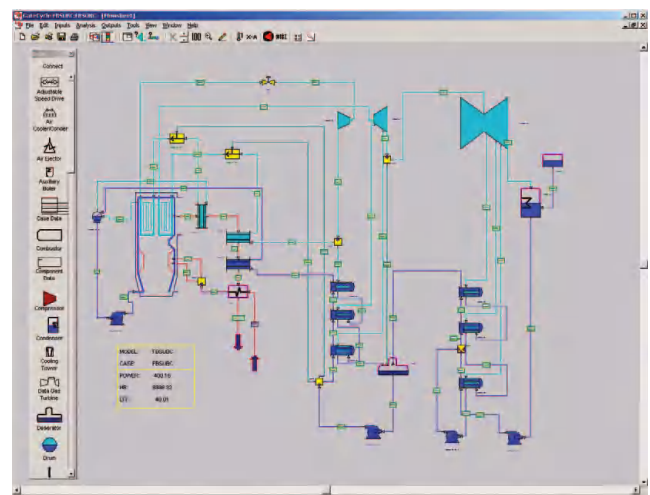

fact sheet

Intuitive graphical model building – Build a model much as you might build a diagram in your favorite slide presentation or graphics software. Simply select a component from the drop-down equipment list, drag it onto the model diagram, and connect components by dragging and dropping graphical stream symbols onto your diagram.

Easy to enter data for model – Simply double-click on the component icon to activate its input screen. The guided data entry features of GateCycle software show which fields require input, which fields contain default values (GateCycle pre-populates many fields with reasonable default values), and which fields have been changed from the default value. The system's flexibility allows SI units, British units, and even user-defined units of measurement. Interface tools tips and an easy-to-use on-line help system are also available to help users establish their models.

Powerful and robust interface to Microsoft® Excel – Users can easily exchange the full set of variables in their model database between GateCycle and Excel, to run and control GateCycle calculations from within an Excel spreadsheet, to perform automated parameter studies using the interface's built-in tools, and to link the inputs and results in GateCycle with additional calculations and reports within Excel.

Widely Used – Because GateCycle is used within GE and by the world's leading OEMs, engineering companies, utilities, and research institutions, over 250 companies in all, we receive ongoing feedback that helps us continually improve and extend its capabilities.

Features

- **Mixed Design/Off-Design Analysis** – design and off-design is completely integrated. Design new equipment around existing components for re-powering/retrofitting studies, for advanced turbomachinery studies, or for acceptance testing
- **Macros and Tables** – customize calculations, input vendor data, or simulate control settings
- **Optimization Tool** – find optimal settings of design parameters, improve measured data by data reconciliation, optimize plant operation
- **Multiple Property Routines** – IAPWS-IF 97, TPSI and others for water/steam; JANAF tables, or even real gas equations for air, combustion products and fuel gases; saltwater properties
- **Gas Turbine Library** – performance data from ISO ratings and performance correction curves

Service and Support

GateCycle software includes one year of technical support and program maintenance, and this can be renewed on an annual basis. Technical support is provided via phone, fax, and e-mail, allowing our specialists to assist you in using the software and in resolving convergence problems. Program maintenance includes software upgrades provided via download from our website.

Training for both beginners and advanced users is offered on a regular basis at principle office locations in the USA (Minden, Nevada) and in Europe (Graz, Austria).



Contact your GE Energy representative today for complete product specifications and ordering information at gatecycle@ge.com.

GE Energy gratefully acknowledges the contributions of EPRI to the early development of GateCycle.

* GateCycle is a trademark of General Electric Company.

GEA-14291 Rev NC (11/2005)