

GE Energy's FC* family of distributing valves is designed to operate in a wide range of hydro turbines. Available for use with hydro turbines built by all manufacturers, the FC flow control valve operates in hydraulic systems with a pressure range of 10 to 138 bar (145 to 2,000 psi) and flows up to 23,700 liters/minute (6,260 gpm). This scalable solution, which includes the FC1250, FC5000, and FC20000, can be customized to operate seamlessly with your analog or digital control system.

Minimized Maintenance Time & Expense

The FC family of valves operates reliably over time, improving availability with decreased maintenance requirements. The FC valves operate securely and safely at maximum flow settings by using simplified hydraulic passages, simple main valve timing adjustments, and solid clamping provisions. The oil cleanliness control system delivers improved filtration for all pilot operated devices, aiding in extended equipment life and greater reliability for all pilot control devices. The duplex filtering system also allows a filter to be changed without interruption of system operation.

General Specifications

- Two-stage, zero lap, hydraulic amplifier valve and industry-standard first stage proportional/pilot valve
- Electronic position feedback to proportional/pilot valve's electronic summing point
- Horizontal mounting to accommodate air bleed system on proportional/pilot valve filters
- Maximum fixed flow adjustments with solid locking nuts
- Duplex proportional/pilot valve filters with electrical or mechanical dirty filter monitors
- Ambient Temperature: 0°C to 50°C (32°F to 122°F)



Overview of Features

- Interfaces with analog or digital control systems
- Compact, modular design
- Minimized maintenance
- Designed to be leak proof
- Simple shutdown system
- Effective filtration system for extended equipment life
- Low governor oil consumption

Benefit Highlights

- Greater operational efficiency through more precise water usage
- Enhanced operating revenue through decreased maintenance costs
- Improved turbine availability through minimized downtime and simplified maintenance
- Sustained ability to meet energy demands



product overview



FC Product Overview

	FC1250	FC5000	FC20000
Weight	70kg	140kg	450kg
Depth	43cm	55cm	81cm
Width	51cm	69cm	102cm
Height	38cm	50cm	76cm

FC1250/5000/20000 Outline Diagram

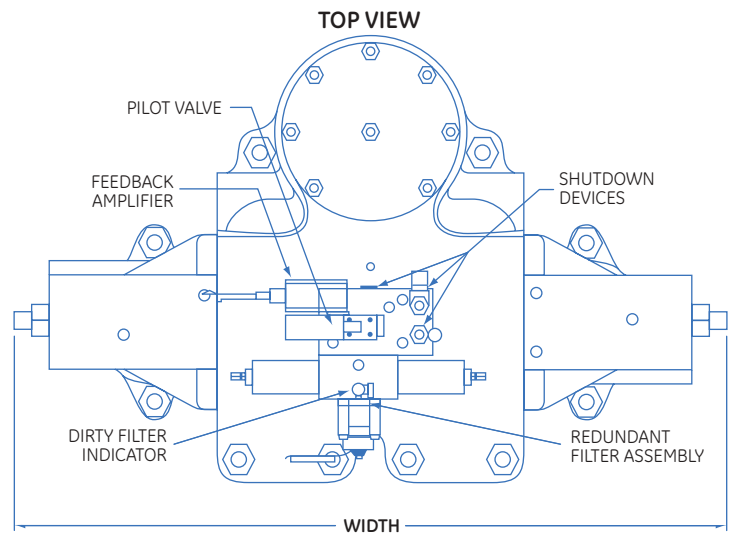
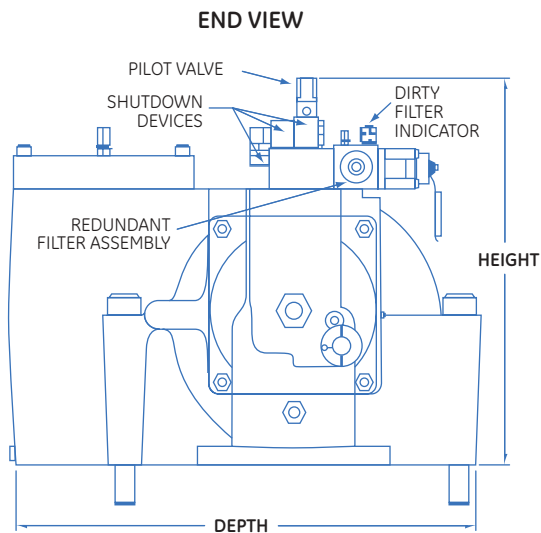

Basic Features

- Turbine shutdown on loss of input current
- Hydraulically applied shut-off plunger to allow shut-off of the main inlet valve
- Field-proven hardware
- Duplex oil filters with either electrical or mechanical dirty filter monitors
- Several shutdown methods, including:
 - Remote hydraulic valve, such as hydro-mechanical overspeed protection device
 - Integrated solenoid valve
 - Integrated manually operated hydraulic valve
 - Command signal to the transducer valve
 - Fail-safe shutdown on loss of power to the transducer valve
- Electrical connection by seven pin DIN connectors on the proportional/pilot valve and the duplex filter
- Typical accuracy is 0.1% of output of servomotor stroke



GE Energy
 3800 North Wilson Avenue
 Loveland, CO 80538
 800-835-5182 / +1-970-461-5201

www.gepower.com/controlsystems

* FC is a trademark of the General Electric Company.

GEA-14037 Rev NC (04/2005)