

# 1701/25 FieldMonitor™ Seismic Input Monitor for Velocity and Acceleration Input

Bently Nevada™ Asset Condition Monitoring

---

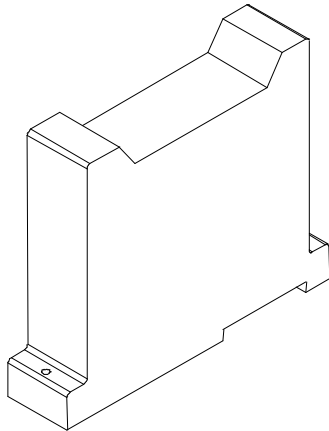

## Description

The 1701/25 FieldMonitor™ Seismic Input Monitor is a 2-channel device that accepts signals from acceleration or velocity transducers via its associated transducer I/O module, conditions these signals into the appropriate measurement units, compares them to user-programmable alarm setpoints, and generates appropriate alarm signals for communication to the host control system. Numerous filtering and integration capabilities are provided for appropriate signal conditioning (refer to specifications for details). The monitor can also provide current values of its measured parameters to the control system for indication and trending. Embedded self-tests permit the monitor to assess its own integrity, and that of its connected transducers. A NOT OK condition can be detected and annunciated when problems with the monitor or its connected transducers exist.

The monitor can be programmed to provide any of the following measurements:

- direct velocity
- rms velocity
- integrated velocity
- filtered direct velocity
- filtered rms velocity
- filtered integrated velocity
- direct acceleration
- rms acceleration
- filtered direct acceleration
- filtered rms acceleration
- integrated direct acceleration (velocity)
- integrated rms acceleration
- filtered integrated direct acceleration
- filtered integrated rms acceleration

**Note:** Velocity and acceleration transducers cannot be mixed in the same 2-channel monitor. Each monitor channel can only provide one of the above measurements, depending on configuration.

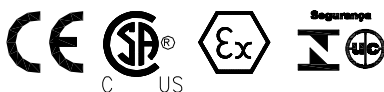

---

Specifications and Ordering Information  
Part Number 141484-01  
Rev. C (11/08)

---

## Specifications

### 1701/25 Seismic Input Monitor for Velocity Input

---

#### Programmable Options

##### Proportional Values (one per channel):

- direct velocity
- rms velocity
- integrated velocity
- filtered direct velocity
- filtered rms velocity
- filtered integrated velocity

#### Alarms

##### Alarm 1 (Alert), Alarm 2 (Danger):

Over Alarm 1 & 2 on single proportional value.

##### Alarm Time Delays:

0.15, 0.2, 0.3, 0.5, 0.6, 1.0, 2.0, 3.0, 5.0, 6.0, 10.0, 20.0 seconds

##### Latching/Non-Latching Alarms:

Non-Latching only

##### Trip Multiply:

None, 1.5, 2, 3

##### OK Mode:

Non-latching only

##### Timed OK Channel Defeat:

Enabled or Disabled

##### Alarm Hysteresis:

0.5% of full-scale

---

#### Signal Processing Options

##### Bandwidth/

##### Filtering

##### Direct Velocity:

3 Hz to 5,500 Hz

##### Direct rms or integrated direct velocity:

10 Hz to 5,500 Hz

##### Filters:

Programmable low-pass (LP) and high-pass (HP) 4<sup>th</sup> order (-80 dB/ decade)

##### Filter Programmable Options

##### High-Pass Corner Frequency in Hz

3, 10, 15, 18, 20, 25, 30, 50, 60, 80, 100, 110, 120

##### Low-Pass Corner Frequency in Hz

5500, 4000, 3000, 2000, 1600, 1400, 1200, 1000, 800, 600, 450, 400, 200, 120, 100

**Note:** The allowed programmable corner frequencies depend on the transducer type and the full-scale range.

##### Full-scale Ranges

##### Peak velocity (no integration):

0 - 0.5 in/s  
0 - 1.0 in/s  
0 - 2.0 in/s  
0 - 3.0 in/s  
0 - 10 mm/s  
0 - 20 mm/s  
0 - 50 mm/s

<b>Integrated velocity, pp:</b>	0 - 75 mm/s
	0 - 5 mil
	0 - 10 mil
	0 - 20 mil
	0 - 100 μm
	0 - 200 μm
	0 - 500 μm
<b>RMS velocity:</b>	
	0 - 0.5 in/s rms
	0 - 1.0 in/s rms
	0 - 2.0 in/s rms
	0 - 3.0 in/s rms
	0 - 10 mm/s rms
	0 - 20 mm/s rms
	0 - 40 mm/s rms
	0 - 50 mm/s rms
	0 - 75 mm/s rms

- Barriers:**
- 170190-01 for all sensors except CEC**
- 170190-02 only for CEC transducers**
- Internal galvanically isolated barrier (requires the 1701/06 Isolator Terminal Base)
  - External Zener Barrier (Velomitors Only)
  - External galvanically isolated barrier

**Supported Transducer I/O Modules**

<b>170180-03-XX</b>	Velomitor® I/O
<b>170180-02-XX</b>	Velocity I/O
<b>170180-04-XX</b>	Velomitor® A and Velocity B I/O

---

**External Transducer Options**

**I/O Module**

**170180-03-XX**  
or  
**170180-04**  
**Channel A only**

Velomitor® transducer

**170180-03-XX**  
or  
**170180-04**  
**Channel A only**

High Temperature Velomitor® transducer

**170180-02-XX**  
or  
**170180-04**

CEC 4 - 126, Moving coil Velocity transducer (When using Internal Galvanic Isolators, this transducer must be used with the 170190-02 isolator)

**170180-02-XX**  
or  
**170180-04**

9200 Series Seismoprobe Velocity transducer (use with 170190-01 isolator)

- 
- Control I/O**
- Channel On/Off
  - Monitor Reset
  - Channel Inhibit
  - Trip Multiply: Enabled, Disabled

---

**Specifications at 25°C (77°F)**

**Direct accuracy:**

1% of full-scale for full-scale ranges with voltage spans > 200mVp.

2% of full-scale for full-scale ranges with voltage spans =200mVp.

(exclusive of filters)

Specifications and Ordering Information  
Part Number 141484-01  
Rev. C (11/08)

<b>Direct resolution:</b>	0.1% of full-scale
<b>Power input:</b>	-24 V, + 5 V, from 1701 Power Supply
<b>Power Consumption:</b>	1.5 Watt (not including transducers)
<b>Setpoint resolution:</b>	0.5% of full-scale
<b>Flex read/write rate:</b>	≥ 25 millisecc (monitor to Flex adapter)
<b>Buffered Output (Buffered signal is unprocessed transducer signal):</b>	30 m (100 ft) cable at 60pF/ft, not isolated
<b>Output impedance:</b>	200 Ω

---

<b>Physical Dimensions (HxWxD)</b>	
	127 mm x 21.6 mm x 105 mm (5 in x 0.85 in x 4.15 in)
<b>Weight:</b>	314 g (0.69 lb)

---

<b>Environmental Limits</b>	
<b>Operating Temperature:</b>	-20°C to + 70°C (-4°F to +158°F)
<b>Storage Temperature:</b>	-40°C to + 85°C (-40°F to +185°F)

<b>Operating Humidity:</b>	5% to 95% non-condensing relative humidity.
<b>Storage Humidity:</b>	5% to 95% non-condensing relative humidity.

---

### 1701/25 Seismic Input Monitor for Acceleration Input

#### Programmable Options

#### Proportional Values (one per channel):

- direct acceleration
- rms acceleration
- filtered direct acceleration
- filtered rms acceleration
- integrated direct acceleration (velocity)
- integrated rms acceleration
- filtered integrated direct acceleration
- filtered integrated rms acceleration

#### Alarms

#### *Alarm 1 (Alert), Alarm 2 (Danger):*

Over Alarm 1 & Alarm 2 on single proportional value

#### *Alarm Time Delays:*

0.15, 0.2, 0.3, 0.5, 0.6, 1.0, 2.0, 3.0, 5.0, 6.0, 10.0, 20.0 seconds

#### *Latching/Non-Latching Alarms:*

Non-Latching only

**OK Mode:**  
Non-Latching only

**Trip Multiply:**  
None, 1.5, 2, 3

**Timed OK Channel Defeat:**  
Enabled or Disabled

**Alarm Hysteresis:**  
0.5% of full-scale

---

### Signal Processing Options

#### Conversions

*(Integrator position with respect to filtering: Filters before integrator only):*

Integrated  
rms

---

#### Bandwidth/Filtering

**Two channels of acceleration input**  
**Output type:**

Selectable Filter Ranges (HP to LP)

**Peak acceleration:**  
3 Hz to 31.55 kHz

**rms acceleration:**  
10 Hz to 31.55 kHz

**Peak velocity:**  
20 Hz to 14.05 kHz

**rms velocity:**  
20 Hz to 14.05 kHz

**One channel acceleration input, one channel unused**  
**Output type:**

Selectable Filter Ranges (HP to LP)

**Peak acceleration:**  
3 Hz to 24.3 K Hz

**rms acceleration:**  
10 Hz to 24.3 K Hz

**Peak velocity:**  
20 Hz to 24.3 K Hz

**rms velocity:**  
20 Hz to 24.3 K Hz

**Filters:**  
Programmable low-pass (LP) and high-pass (HP) 4<sup>th</sup> order  
(-80 dB/ decade)

---

#### Filter Programmable Options

##### Dual-Channel 14.05 kHz Accel Monitor Type 1

###### High-Pass

###### Corner

###### Frequency in Hz

3, 10, 12, 16, 20, 22, 25, 30, 50, 60, 100, 120, 150, 200

###### Low-Pass

###### Corner

###### Frequency in Hz

14050, 13200, 12100, 10600, 10000, 9000, 8100, 7000, 6100, 5000, 4100, 3100, 2100, 1100

##### Dual-Channel 31.55 kHz Accel Monitor Type 2

###### High-Pass

###### Corner

###### Frequency in Hz

3, 10, 12, 16, 20, 22, 25, 30, 50, 60, 100, 120, 150, 200

###### Low-Pass

###### Corner

###### Frequency in Hz

31550, 26000, 23700, 15800, 13250, 12100, 10600, 10000, 8100, 6000, 5000, 3000, 2100, 1000

### Single-Channel 24.3 kHz Accel Monitor Type 3

#### High-Pass

#### Corner

#### Frequency in Hz

3, 10, 12, 16, 20, 22, 25, 30, 50, 60,  
100, 120, 150, 200

#### Low-Pass

#### Corner

#### Frequency in Hz

24300, 21000, 18000, 15800,  
13250, 12100, 10600, 10000,  
8100, 6000, 5000, 3000, 2100,  
1000

**Note:** The allowed programmable corner frequencies depend on the channel type and the full-scale range type.

---

### Full Scale Ranges

#### Peak

#### acceleration,

#### no integration:

0 - 2 g's pk  
0 - 5 g's pk  
0 - 10 g's pk  
0 - 20 g's pk  
0 - 25 g's pk  
0 - 40 g's pk  
0 - 50 g's pk  
0 - 20 m/s<sup>2</sup> pk  
0 - 50 m/s<sup>2</sup> pk  
0 - 100 m/s<sup>2</sup> pk  
0 - 200 m/s<sup>2</sup> pk  
0 - 250 m/s<sup>2</sup> pk  
0 - 400 m/s<sup>2</sup> pk  
0 - 500 m/s<sup>2</sup> pk

#### Integrated acceleration, pk:

0 - 1.0 in/s pk  
0 - 2.0 in/s pk  
0 - 25 mm/s pk

0 - 50 mm/s pk

0 - 100 mm/s pk

#### RMS

#### acceleration

0 - 2 g's rms  
0 - 5 g's rms  
0 - 10 g's rms  
0 - 20 g's rms  
0 - 25 g's rms  
0 - 40 g's rms  
0 - 50 g's rms  
0 - 20 m/s<sup>2</sup> rms  
0 - 50 m/s<sup>2</sup> rms  
0 - 100 m/s<sup>2</sup> rms  
0 - 200 m/s<sup>2</sup> rms  
0 - 250 m/s<sup>2</sup> rms  
0 - 400 m/s<sup>2</sup> rms  
0 - 500 m/s<sup>2</sup> rms

#### RMS integrated acceleration:

0 - 1.0 in/s rms  
0 - 2.0 in/s rms  
0 - 25 mm/s rms  
0 - 50 mm/s rms  
0 - 100 mm/s rms

---

#### Barriers:

- Internal galvanically isolated barrier (requires the 1701/06 Isolator Terminal Base)
- External Zener Barrier
- External galvanically isolated barrier

---

### Supported Transducer I/O Modules

#### 170180-01-XX

Dual Proximito®/Accelerometer I/O Module (for external -24 V BNC Accelerometer Interface Modules excluding Aero GT)

---

## External Transducer Options

\*23733-03

100 mV/g pk

\*24145-02

High frequency acceleration

49578-01

100 mV/g pk

\*155023-01

High frequency acceleration

330400

100 mV/g pk

330425

25 mV/g pk

\* **Note:** These products are not recommended for new designs because they are in the early stages of planned obsolescence. Use 330400 and 330425 acceleration systems where feasible.

---

## Control I/O

- Channel On/Off
- Monitor Reset
- Channel Inhibit
- Trip Multiply: Enabled, Disabled

---

## Specifications at 25°C (77°F)

### Direct accuracy:

1% of full-scale for full-scale ranges with voltage spans >200mVp.

2% of full-scale for full-scale ranges with voltage spans =200mVp.

(exclusive of filters)

### Direct resolution:

0.1% of full-scale

### Power input:

-24 V, + 5 V, from 1701 Power Supply

### Power Consumption:

1.5 Watt (not including transducers)

### Setpoint resolution:

0.5% of full-scale

### Flex read/write rate:

≥ 25 millisecc (monitor to Flex adapter)

### Buffered Output (Buffered signal is unprocessed transducer signal):

30 m (100 ft) cable at 60pF/ft, not isolated

### Output impedance:

200 Ω

---

## Physical

### Dimensions (HxWxD)

127 mm x 21.6 mm x 105 mm  
(5 in x 0.85 in x 4.15 in)

### Weight:

314 g (0.69 lb)

---

## Environmental Limits

### Operating Temperature:

-20°C to + 70°C (-4°F to +158°F)

### Storage Temperature:

-40°C to + 85°C (-40°F to +185°F)

### Operating Humidity:

5% to 95% non-condensing relative humidity.

### Storage Humidity:

5% to 95% non-condensing relative humidity.

---

## Ordering Information

FieldMonitor™ Seismic Input Monitor  
for Velocity and Acceleration Input  
1701/25-01

---

## Hazardous Area Approvals

### North America

Ex nA IIC T4  
Class I, Zone 2  
Class I, Div 2  
Groups A, B, C, D  
T4 @ -30°C = Ta = +70°C  
Per drawing # 139255

*Certification  
Number*

CSA 1166985

### European/ATEX

 II 3G EEx nA [L] IIC T4  
LCIE 00ATEX6016X  
T4 @ -30°C = Ta = +70°C

 II 1/3 G EEx nA[ia] ia IIC T4  
LCIE 00ATEX6017X  
T4 @ -30°C = Ta = +70°C

### Brazil

Br-Ex nA [nL] IIC T4  
MC, AEX-8304-X  
T4 @ -30°C = Ta = +70°C

## Dimensional Drawing

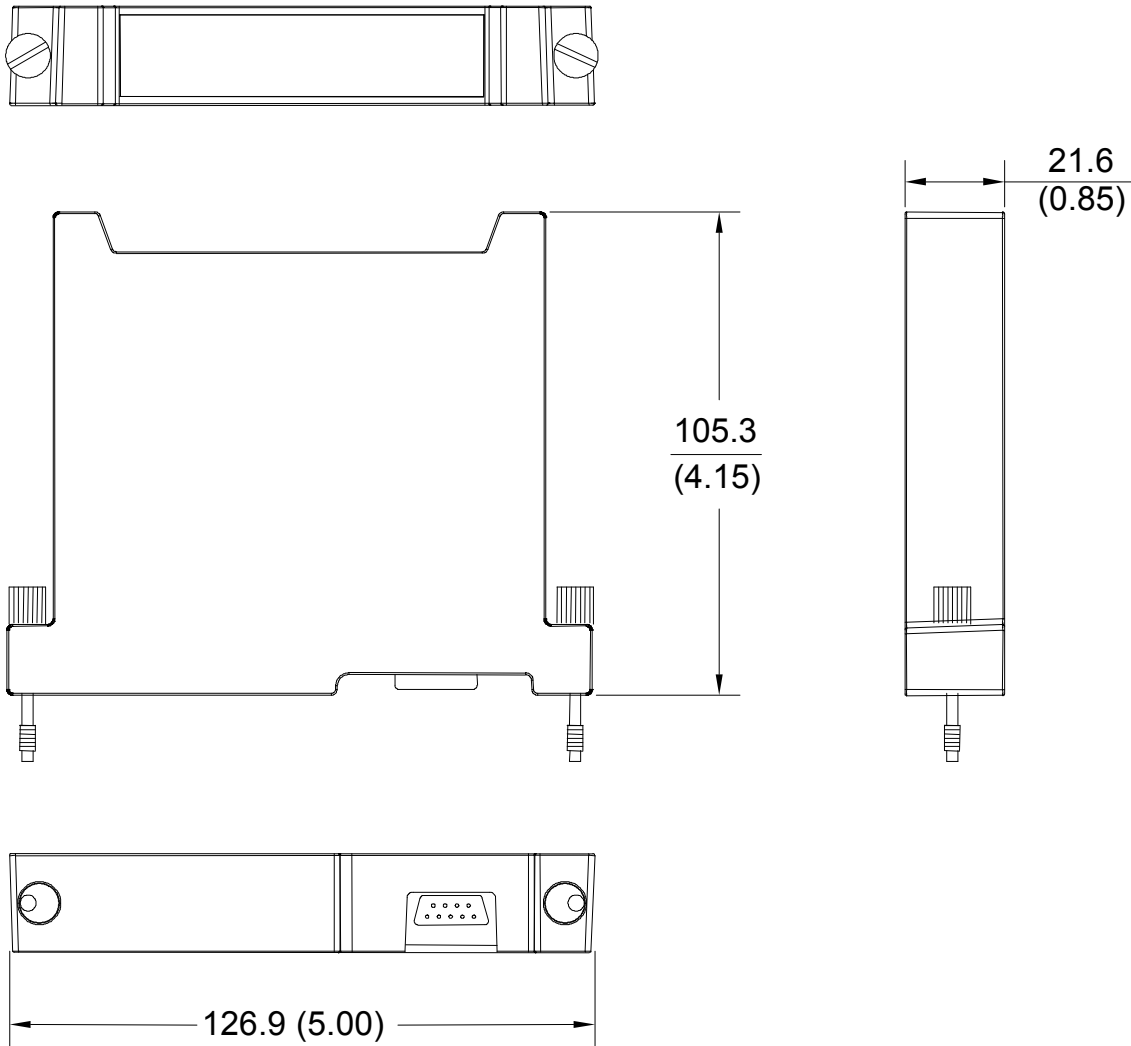

Dimensions are in millimetres (inches)

Bently Nevada, FieldMonitor, Proximitor and NSv are trademarks of General Electric Company.

Copyright 1999. Bently Nevada LLC.  
1631 Bently Parkway South, Minden, Nevada USA 89423  
Phone: 775.782.3611 Fax: 775.215.2873  
[www.ge-energy.com/bently](http://www.ge-energy.com/bently)  
All rights reserved.

Specifications and Ordering Information  
Part Number 141484-01  
Rev. C (11/08)