

330450 High Temperature Acceleration System

Bently Nevada™ Asset Condition Monitoring

Description

The standard 330400 Accelerometer has a limited temperature range it can be exposed to, due to its signal conditioning electronics being located in the same case as the sensing element. Temperature limitations of the electronics limit its maximum operating temperature to +121°C (+250°F).

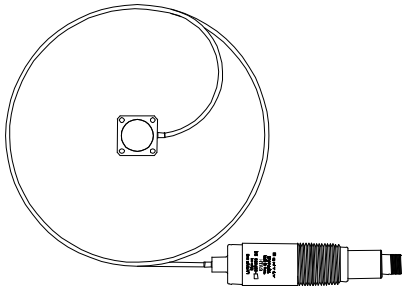

The 330450 High Temperature Acceleration System (HTAS) has a fundamentally different construction to solve this problem. Its design segregates the sensing element from the signal conditioning electronics, with the two permanently connected via a hardline cable. Current versions (see note below) of these sensors allow the sensing head to be mounted on surfaces with temperatures as high as +400°C (+752°F). Due to the segregated design, the signal conditioning electronics can be installed in a cooler location. This achieves overall transducer system performance comparable to other acceleration transducers, but permits use at significantly higher temperatures. By eliminating connections between the sensing head and its associated signal conditioning electronics, a significant source of potential transducer failures (connector problems) is eliminated.

Caution

If housing measurements are being made for overall protection of the machine, thought should be given to the usefulness of the measurement for each application. Most common machine malfunctions (imbalance, misalignment, etc.) originate at the rotor and cause an increase (or at least a change) in rotor vibration. In order for any housing measurement alone to be effective for overall machine protection, a significant amount of rotor vibration must be faithfully transmitted to the bearing housing or machine casing, or more specifically, to the mounting location of the transducer.

In addition, care should be exercised in the physical installation of the transducer. Improper installation can result in a degradation of the transducer's performance, and/or the generation of signals which do not represent actual machine vibration.

Upon request, Bently Nevada can provide engineering services to determine the appropriateness of housing measurements for the machine in question and/or to provide installation assistance.

Note: The previous version limited the sensor head to +300°C (+572°F). The current versions will have the letter "G" preceding the serial number.



Specifications

Parameters are specified from +20 to +30°C (+68 to +86°F) and 100Hz unless otherwise indicated.

Note: Operation outside the specified limits may result in false readings or loss of machine monitoring.

Electrical

Sensitivity:

10.2 mV/m/s² (100 mV/g) ±5%.

Acceleration range:

785 m/s² (80 g) peak overall acceleration within the 15 to 10000 Hz frequency span.

Amplitude Linearity:

±2% to 785 m/s² (80 g) peak.

Broadband Noise Floor (10 Hz to 15 kHz):

0.059 m/s² (0.006 g) rms.

Frequency Response:

15 to 10000 Hz
(900 to 600,000 cpm) ±3dB;
40 to 4000 Hz
(2400 to 240,000 cpm) ±5%

Transverse Sensitivity:

Less than 5% of axial.

Mounted Resonant Frequency:

Greater than 15 kHz.

Maximum cable length:

305 metres (1000 ft) with no degradation of signal.

Power requirements:

Input Voltage

-24 ± 0.5 Vdc.

Bias Current:

2 mA nominal.

Output Bias Voltage:

-12 ± 0.5 Vdc.

Grounding:

Case isolated.

Hazardous Area Approvals

Multiple approvals for hazardous areas certified by Canadian Standards Association (CSA/NRTL/C) in North America and by LCIE in Europe.

North America:

Ex ia/AEx ia for II C T4
Class I, Div 1
Groups A, B, C, and D;
Class II, Div 1, Groups E, F, and G;
Class III, Div 1, when installed per drawing 168078.
T4 @ Ta (- 40°C to 100°C)

Ex nL II C T4
Class I, Div 2
Groups A, B, C, and D when installed per drawing 168078.
T4 @ Ta (- 40°C to 100°C)

European/CENE LEC:

 II 1 G

EEx ia IIC T4

Tamb.: - 40°C to 100°C

Certificate number

LCIE 04ATEX6140X

Environmental Limits

Operating and storage temperature range

Sensing head:

Maximum mounted surface temperature –55°C to +400°C (–67°F to +752°F)

Integral hardline cable:

–55°C to +400°
(–67°F to +752°F)

Electronics:

–55°C to +121°C
(–67°F to +250°F)

Shock survivability:

24,535 m/s² (2500 g) peak

Relative humidity:

To 100% non-submerged; case is hermetically sealed.

Physical

Weight (typical):

2 metres:

635 grams (1.40 lb)

4 metres:

794 grams (1.75 lb)

6 metres:

953 grams (2.10 lb)

8 metres:

1111 grams (2.45 lb)

Mounting:

See Dimensional Drawing, Figure 1

Case material:

300 series stainless steel.

Connector:

3-pin Mil-C-5015 receptacle, hermetically-sealed, 304 stainless steel shell.

Polarity:

Pin A goes positive with respect to Pin C when the applied force is from the base to the top of the sensing head.

Bend Radius:

Minimum bend radius of 51mm (2.0in)

Note: Please read and understand the User Guide *before* attempting to install and use this product.

Ordering Information

330450-AXX

A: Length

20	2 metres
40	4 metres
60	6 metres
80	8 metres

Graphs and Figures

Dimensional Drawing – 330450

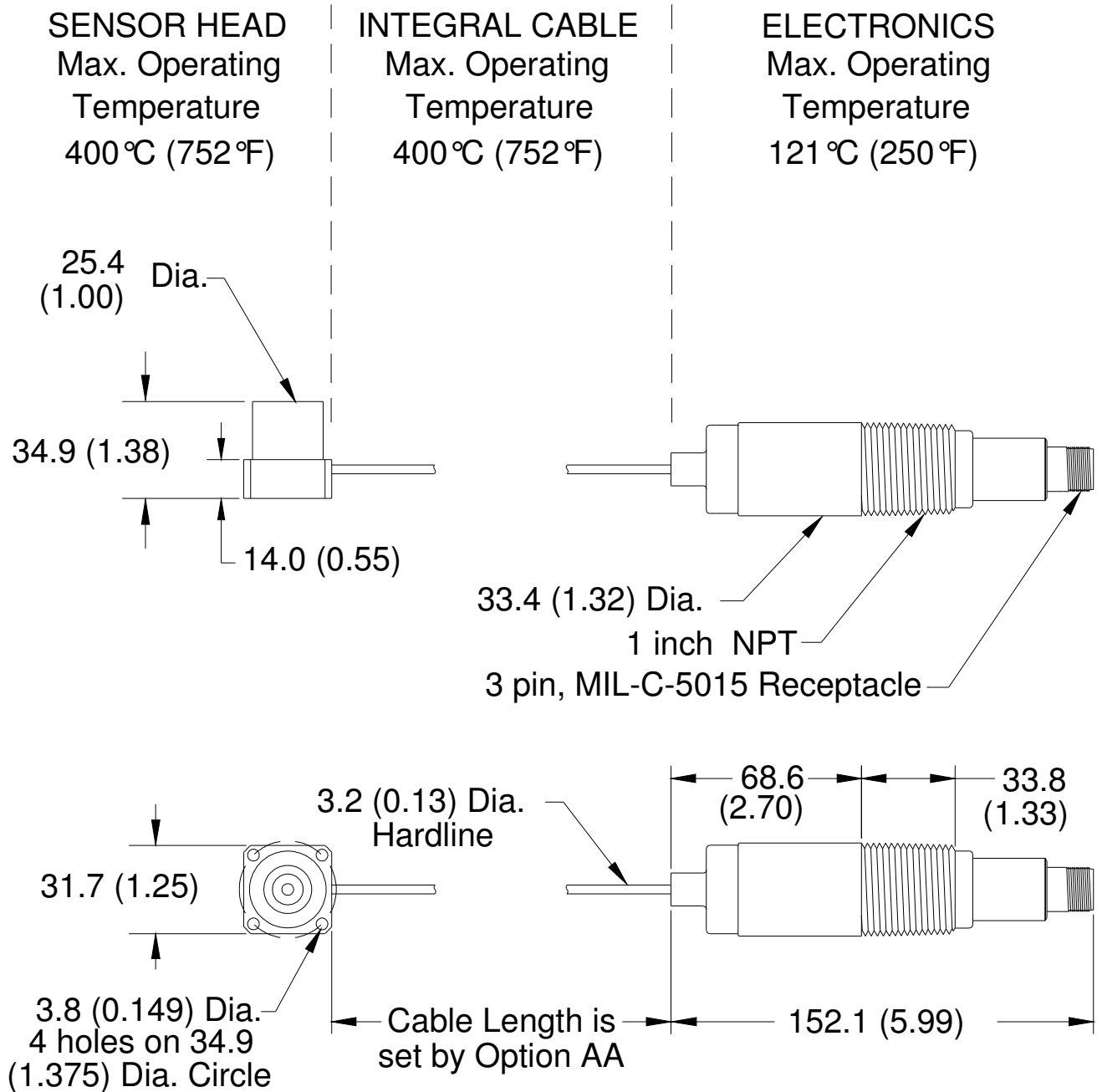

Figure 1: 330450 System Dimensional Drawing
 Dimensions are in millimeters (inches)

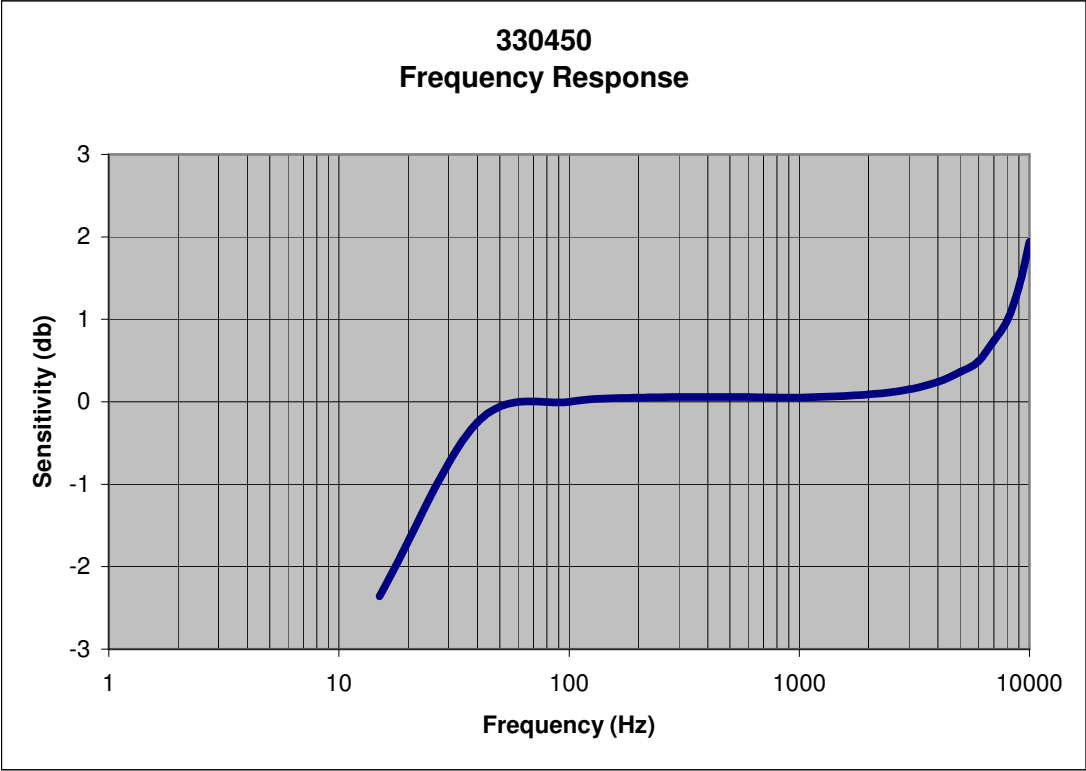

Figure 2: Acceleration Amplitude

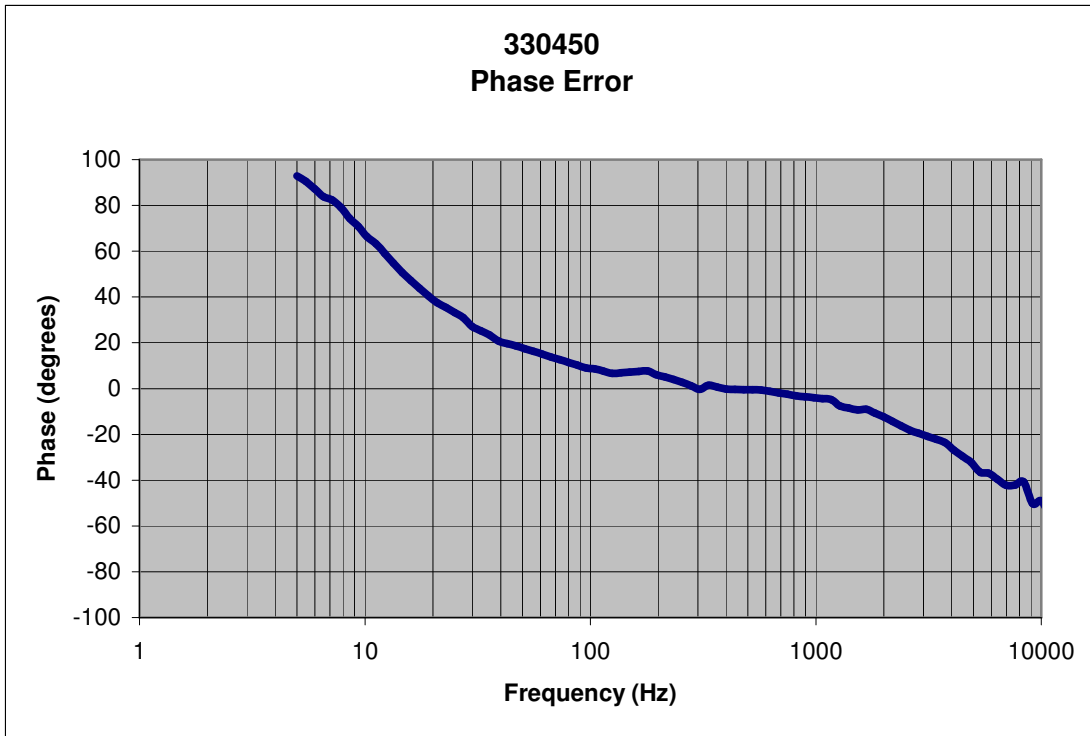
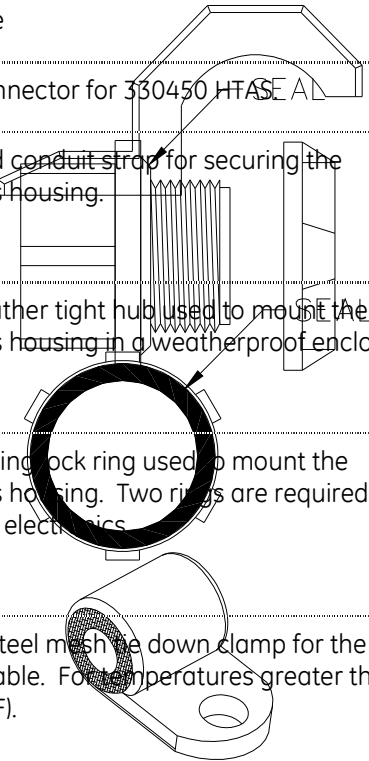

Figure 3: Acceleration Phase Error

Table 1: Interconnection Cables and Accessories

APPLICATION	PART NUMBER	DESCRIPTION
*Note: AA - Specifies the length (in feet) of cable required		
Standard Interconnect Cable	16925-AA*	3-conductor shielded 22 AWG (0.5 mm ²) cable with 3-socket plug at one end, terminal lugs at the other end. Minimum length of 2.0 ft (0.6 m), maximum length of 99 ft (30 m). See Figure 4
Standard Armored Interconnect Cable	16710-AA*	3-conductor shielded 22 AWG (0.5 mm ²) armored cable with 3-socket plug at one end, terminal lugs at the other end. Minimum length of 3.0 ft (0.9 m), maximum length of 99 ft (30 m). See Figure 5
Interconnect Cable with Boot	130539-AA*	3-conductor shielded 18 AWG (1.0 mm ²) cable with 3-socket plug and fluorosilicone elastomer boot at one end, terminal lugs at the other end. Minimum length of 2.0 ft (0.6 m), maximum length of 99 ft (30 m). A manual is available to assist with installation of this cable (part number 133080-01). See Figure 6
330450 Manual	139976-01	User Guide
Spare Mating Connector	00531080	Mating connector for 330450 HTASE AL
Electronics Housing Strap	03818073	1 inch rigid conduit strap for securing the electronics housing.
Electronics Mounting Hub	03818071	1 inch weather tight hub used to mount the electronics housing in a weatherproof enclosure.
Seal Ring	03818072	1 inch sealing lock ring used to mount the electronics housing. Two rings are required to mount the electronics.
Cable Clamp	169546	Stainless steel mesh tie down clamp for the hardline cable. For temperatures greater than 260C (500F).



Cushioned Cable Clamp

169545

Cushioned tie down clamp for the hardline cable.
For temperatures less than 260C (500F).

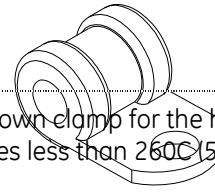

PART NUMBER 16925 - (SEE NOTE)

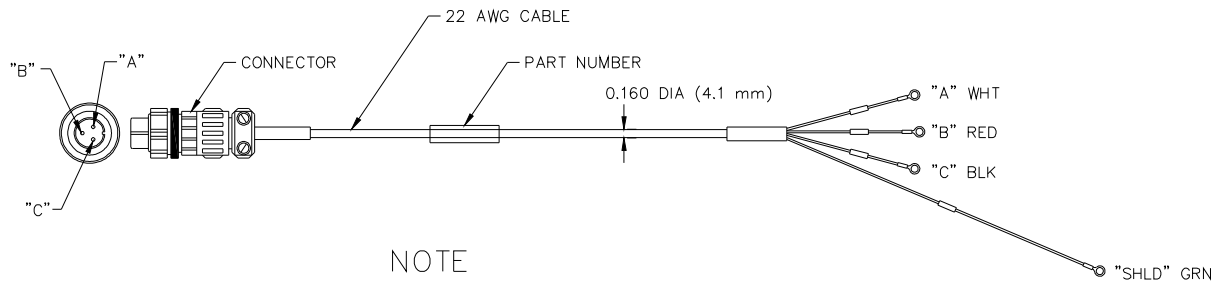

NOTE

INCREMENTS OF 1.0 FOOT (0.30 Metres)
EXAMPLE: <input type="text"/> <input type="text"/> = 2 FEET (0.61 Metres)
<input type="text"/> <input type="text"/> = 25 FEET (7.62 Metres)
MIN LENGTH = 2.0 FEET (0.61 Metres)
MAX LENGTH = 99 FEET (30.18 Metres)

*ALL DIMENSION ARE IN INCHES (MILLIMETRES) UNLESS OTHERWISE SPECIFIED.

Figure 4: Standard Interconnect Cable

PART NUMBER 16710 – (SEE NOTE)

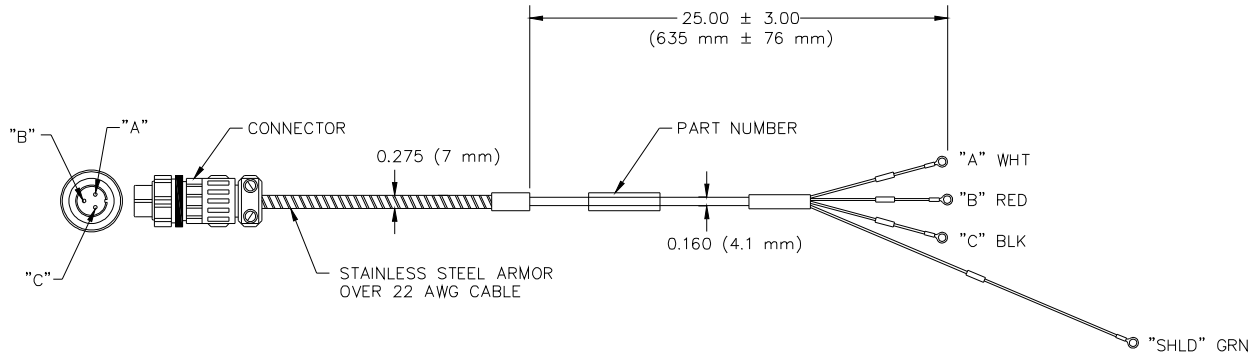

NOTE

INCREMENTS OF 1.0 FOOT (0.30 Metres)
EXAMPLE: <input type="text"/> <input type="text"/> = 3 FEET (0.91 Metres)
<input type="text"/> <input type="text"/> = 25 FEET (7.62 Metres)
MIN LENGTH = 3.0 FEET (0.91 Metres)
MAX LENGTH = 99 FEET (21.34 Metres)

*ALL DIMENSIONS ARE IN INCHES (MILLIMETRES) UNLESS OTHERWISE SPECIFIED.

Figure 5: Standard Armored Interconnect Cable

PART NUMBER 130539 – (SEE NOTE)

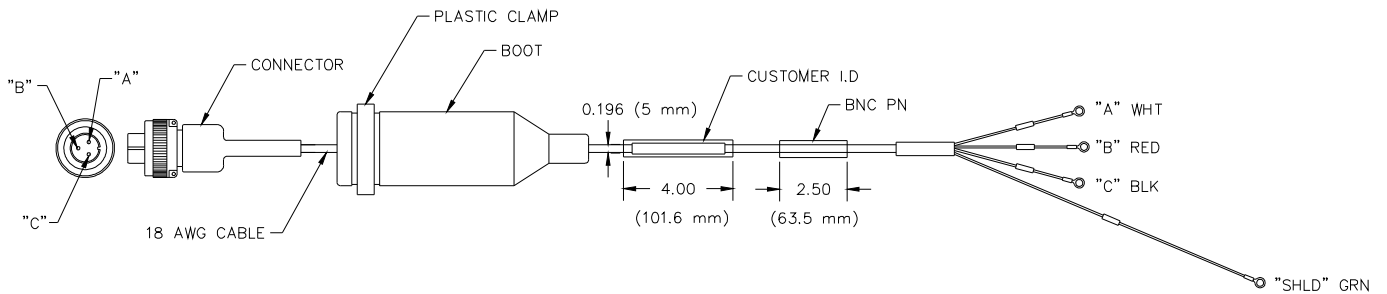

NOTE

INCREMENTS OF 1.0 FOOT (0.30 Metres)
EXAMPLE: <input type="text"/> <input type="text"/> = 12 FEET (3.66 Metres)
<input type="text"/> <input type="text"/> = 25 FEET (7.62 Metres)
MIN LENGTH = 2.0 FEET (0.61 Metres)
MAX LENGTH = 99 FEET (30.18 Metres)

*ALL DIMENSIONS ARE IN INCHES (MILLIMETRES) UNLESS OTHERWISE SPECIFIED

Figure 6: Standard Right Angle Interconnect Cable

Copyright 2005. Bently Nevada LLC.
1631 Bently Parkway South, Minden, Nevada USA 89423
Phone: 775.782.3611 Fax: 775.215.2873
www.ge-energy.com/bently
All rights reserved.

Bently Nevada is a trademark of General Electric Company.