

330505 Low Frequency Velocity Sensor

Bently Nevada™ Asset Condition Monitoring

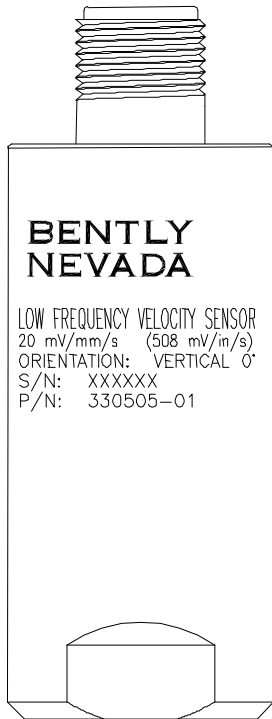

Description

The Bently Nevada Low Frequency Velocity Sensor is designed to measure absolute (relative to free space) bearing housing, casing, or structural vibration. The two-wire system consists of a transducer and appropriate cable.

The Low Frequency Velocity Sensor is ideal for capturing vibration data in installations where vibration frequencies of less than 4 Hz provide valuable data. Its main use is to measure bearing casing vibrations on hydroelectric turbines where slow rotating speeds require a low signal to noise ratio. The 330505 Transducer is a two-wire design that uses moving-coil technology with embedded signal conditioning circuitry to provide a voltage output directly proportional to the transducer's vibration velocity. The 330505 Transducer connects to an interconnect cable and is then directly attached into the 3500/46M Hydro Monitor. This transducer currently does NOT interface with the Trendmaster® family of products. Additionally, due to capacitance constraints, hazardous area approvals will NOT be available on this product.

Caution

Due to the nature of high amplitude, low frequency velocity events, the 330505 Low Frequency Velocity Sensor cannot be used for automated machinery protection. It is designed to provide early warning of pending machinery problems and to assist in diagnosing machinery problems.

In addition, care should be exercised in the physical installation of the transducer. Improper installation can result in a degradation of the transducer's performance, and/or the generation of signals which do not represent actual machine vibration.

Upon request, we can provide engineering services to determine the appropriateness of housing measurements for the machine in question and/or to provide installation assistance.

Note: For the majority of installations, our Velomitor® family of velocity transducers, which incorporate solid-state technology, represent superior performance and robustness for casing velocity measurement applications. However, the sensor family currently has no sensors with a low frequency range similar to the 330505 Low Frequency Velocity Sensor.



imagination at work

Specifications and Ordering Information
Part Number 169872-01
Rev. A (04/07)

Page 1 of 11

Specifications

Parameters are specified from +20 to +30°C (+68 to +86°F) and 80Hz unless otherwise indicated.

Note: Operation outside the specified limits may result in false readings or loss of machine monitoring.

Electrical

Sensitivity:

20 mV/mm/s (508mV/in/s)
±10%

Frequency response:

0.5 to 1000 Hz (30 to 60,000 cpm) ± 3.0 dB;
1 to 200 Hz (60 to 12,000 cpm) ± 0.9 dB

Amplitude range:

See vibration nomograph (Figure 1)

Amplitude linearity:

±3% to 102 mm/s (4 in/s) peak

Maximum cable length:

305 metres (1000 feet)
with no degradation of signal, when used with 3500/46M

Environmental Limits

Operating and storage temperature range

Maximum mounted surface temperature
−40°C to +100°C (−40°F to +212°F)

Shock survivability:

981 m/s² (100g) peak

Relative humidity:

To 100% non-submerged; case is hermetically sealed.

Physical

Weight (typical):

< 375grams (13.2oz)

Mounting:

See Dimensional Drawings, Figure 2

Case material:

300 series stainless steel.

Connector:

2-pin Mil-C-5015 receptacle, hermetically sealed, 300 series stainless steel.

Mounting Torque:

46 kg cm (40 in-lb) max.

Polarity:

Pin A goes positive with respect to Pin B when the applied velocity is from the base to the top of the transducer.

Note: Please read and understand the User Guide *before* attempting to install and use this product.

Ordering Information

330505-AXX-BXX-CXX

A: Transducer Mounting Angle

01 0° ± 10°
02 90° ± 5°
03 180° ± 10°

B: Internal Mounting Thread

02 3/8-24 UNF-2B

C: Mounting Adapter Option

00 No Adapter
01 1/2 - 20 UNF
02 M8 x 1
03 1/4 - 28 UNF
04 1/4 - 20 UNC
05 1/4 - 18 NPT
06 5/8 - 18 UNF
07 3/8 - 16 UNC

Accessories

169873-01

330505 Low Frequency Velocity Sensor Manual

89409-01

Individual 1/2 - 20 UNF mounting adapter.

89410-01

Individual M8 x 1 mounting adapter

89411-01

Individual 1/4 - 28 UNF mounting adapter

89412-01

Individual 1/4 - 20 UNC mounting adapter

89413-01

Individual 1/4 - 18 NPT mounting
adapter

161191

Individual 1/2 - 13 UNC mounting
adapter

04300015

Individual 5/8 - 18 UNF mounting
adapter.

Vibration Nomograph

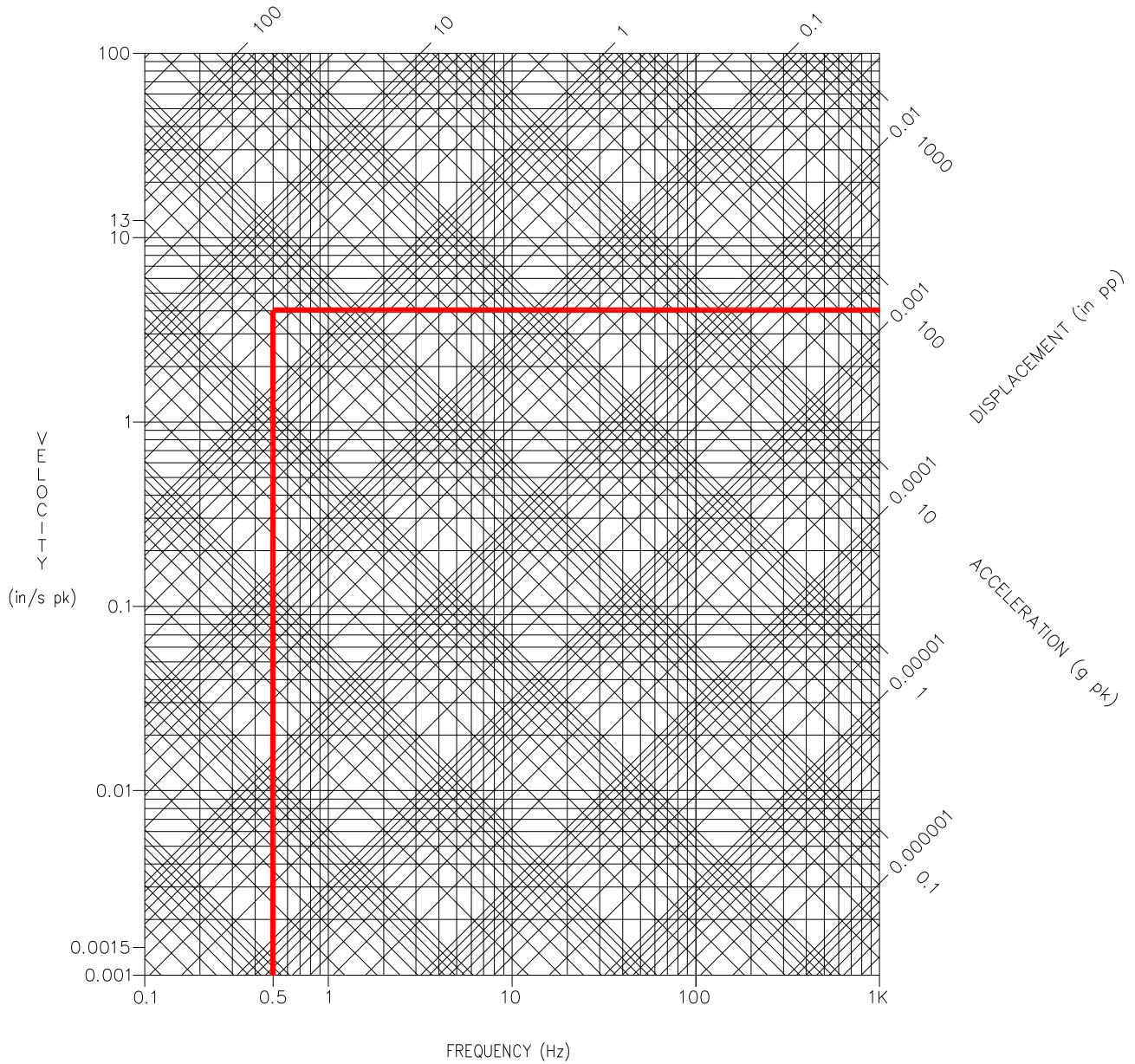

Figure 1: 330505 Vibration Nomograph

Dimensional Drawing – 330505

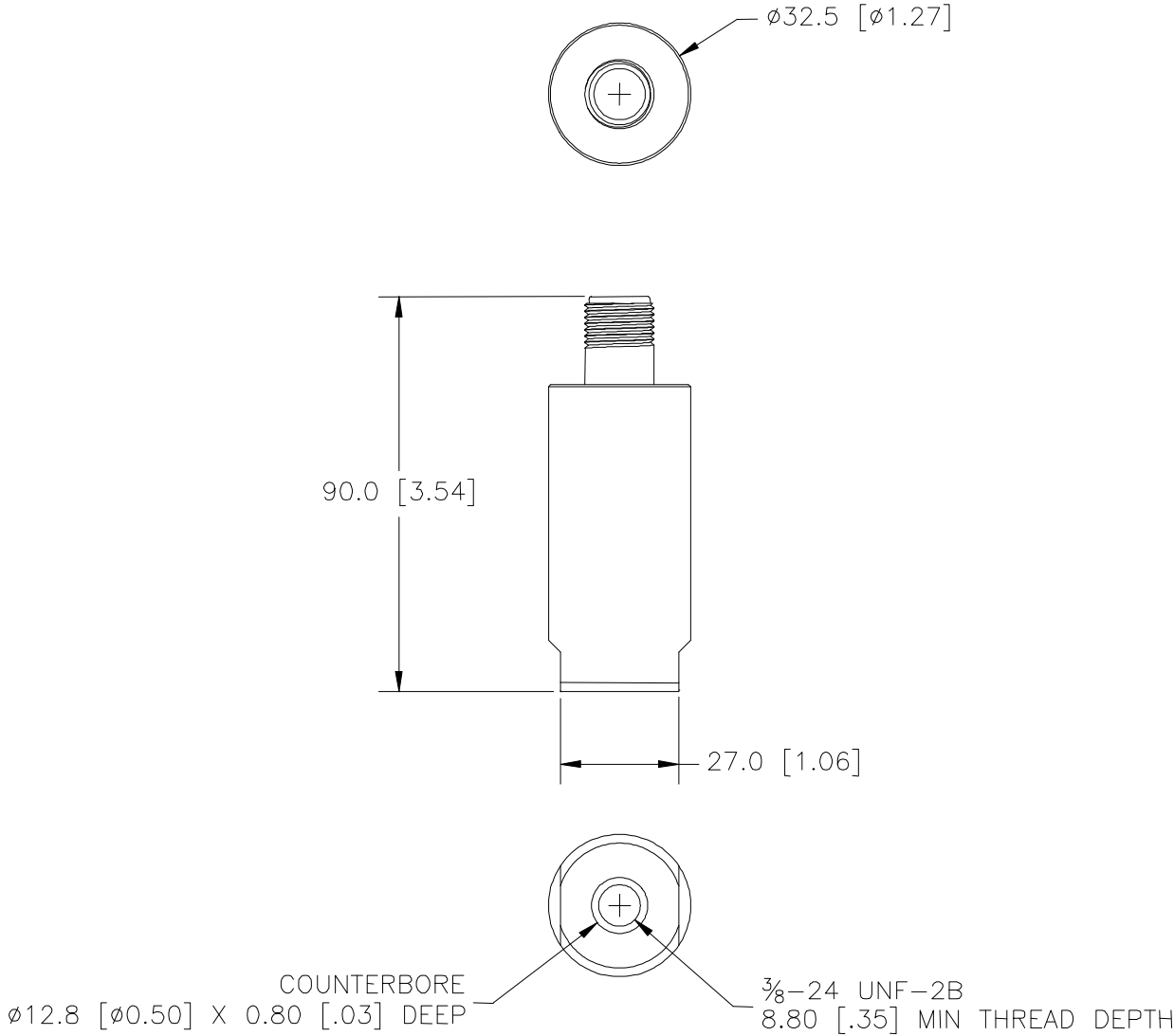

Figure 2: 330505 System Dimensional Drawing
Dimensions are in millimeters (inches)

Graphs - 330505 Typical Response

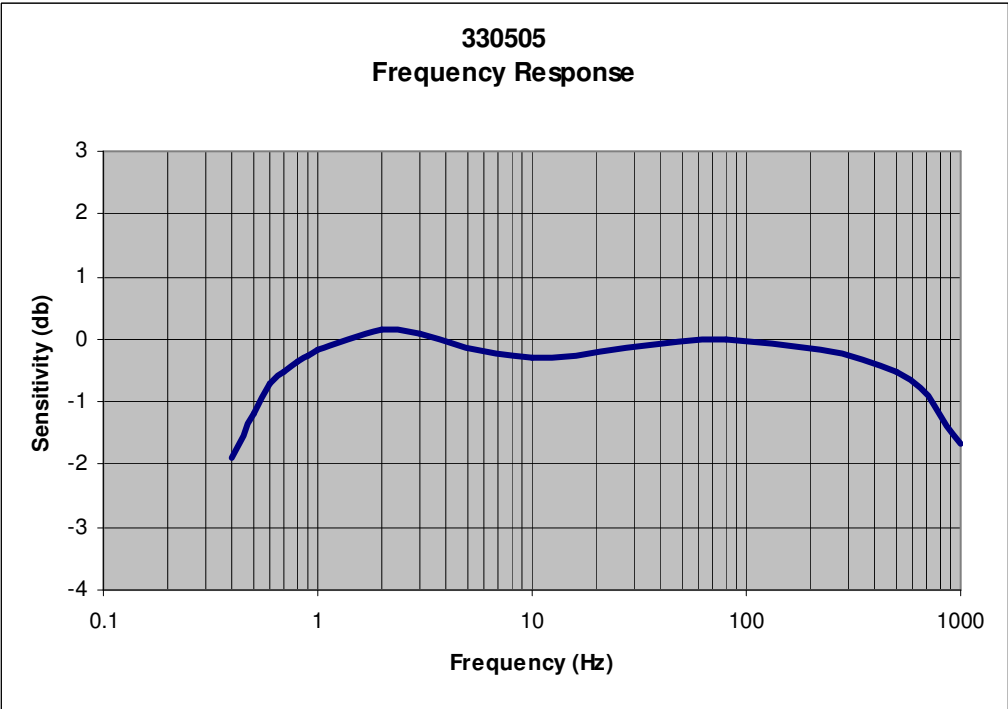

Figure 3: Typical Velocity

Amplitude

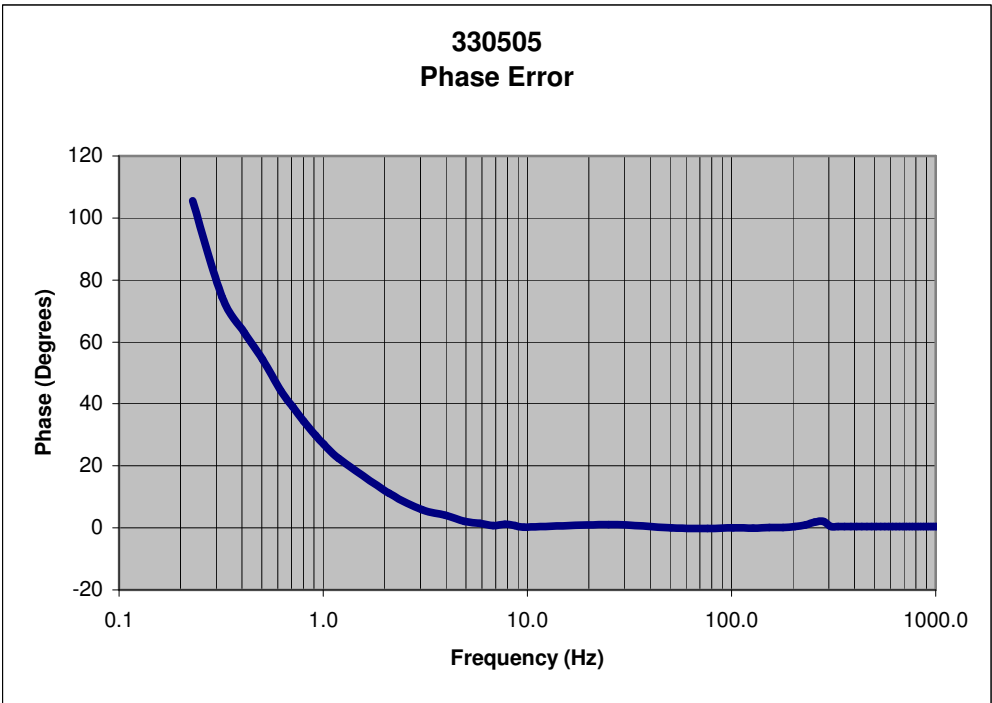

Figure 4: Typical Velocity Phase Error

Table 1: Interconnection Cables and Accessories

APPLICATION	PART NUMBER	DESCRIPTION
*Note: AA - Specifies the length (in feet) of cable required		
Splash Proof Interconnect Cable (*Recommended for High Electromagnetic Noise Environment and European Conformance (CE))	02173034	Shielded 0.382 mm ² (22 AWG) cable with a splash proof boot over a female connector at the transducer end and flush cut at the monitor end. Temperature range -55 to 125°C (-67 to 257°F). See Figure 5
Splash Proof Interconnect Cable	CB2W100-AA*	Shielded 0.382 mm ² (22 AWG) cable with splash proof over molded boot, blunt cut at the monitor end. Temperature range -50 to 200°C (-58 to 392°F). See Figure 6
Standard Interconnect Cable	9571-AA*	Shielded 0.382 mm ² (22 AWG) cable with a moisture resistant female connector at the transducer end and ring lugs at the monitor end. Temperature range -29 to 121°C (-20 to 250°F). See Figure 7
Standard Armored Interconnect Cable	84661-AA*	Stainless steel armor over shielded 0.382 mm ² (22 AWG) cable with a moisture resistant female connector at the transducer end and ring lugs at the monitor end. Temperature range -29 to 121°C (-20 to 250°F). See Figure 8
Right Angle Interconnect Cable	89477-AA*	Shielded 0.963 mm ² (18 AWG) cable with a moisture resistant right angle female connector at the transducer end and ring lugs at the monitor end. Temperature range -29 to 121°C (-20 to 250°F). See Figure 9
Short Run Interconnect Cable	122129-AA*	Shielded 0.963 mm ² (18 AWG) cable with a moisture resistant female connector at the transducer end and ring lugs at the monitor end. Temperature range -29 to 121°C (-20 to 250°F). See Figure 10
0.963 mm ² (18 AWG) Bulk Cable	02173006	Shielded twisted pair. Same cable as used on 89477-AA and 122129-AA. Specify number of feet.
0.382 mm ² (22 AWG) Bulk Cable	02173007	Shielded twisted pair. Same cable as used on 9571-AA and 84661-AA. Specify the number of feet. The maximum length that should be used with the transducer is 305 m (1000 ft)
Spare Connector	00502025	Same connector as used on 9571-AA and 84661-AA
Right Angle Connector	101212-01	Right angle connector kit. Same connector as used on 89477-AA.

PART NUMBER 02173034

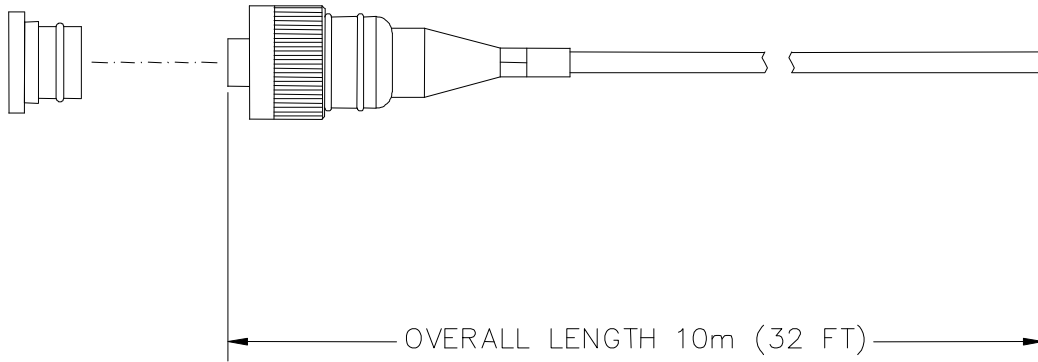

Figure 5: Splash Proof Interconnect Cable

P/N: CB2W100 – AAA

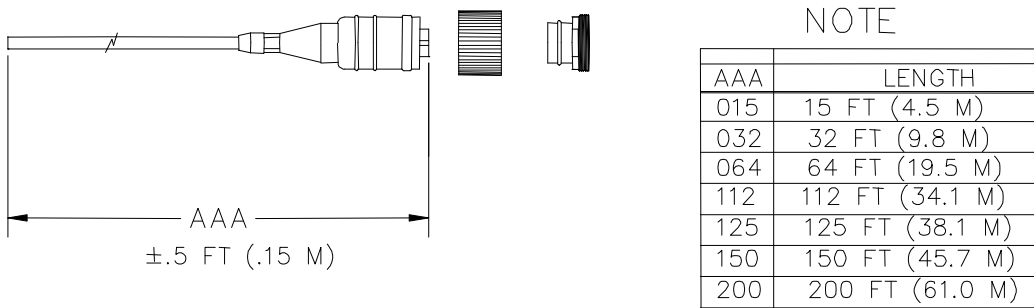
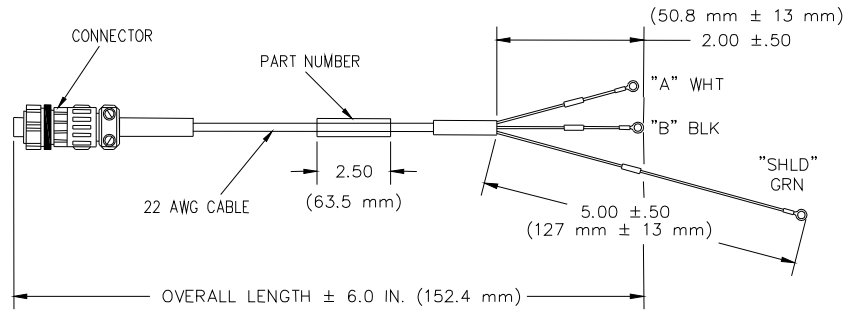

Figure 6: Splash Proof Interconnect Cable

PART NUMBER 9571 – (SEE NOTE)



NOTE

ORDER IN INCREMENTS OF 1.0 FOOT (0.30 m)
EXAMPLE: <input type="text" value="02"/> = 2 FEET (0.60 m)
<input type="text" value="25"/> = 25 FEET (7.6 m)
MIN LENGTH = 2.0 FEET (0.60 m)
MAX LENGTH = 99 FEET (30 m)

Figure 7: Standard Interconnect Cable

PART NUMBER 84661 – (SEE NOTE)

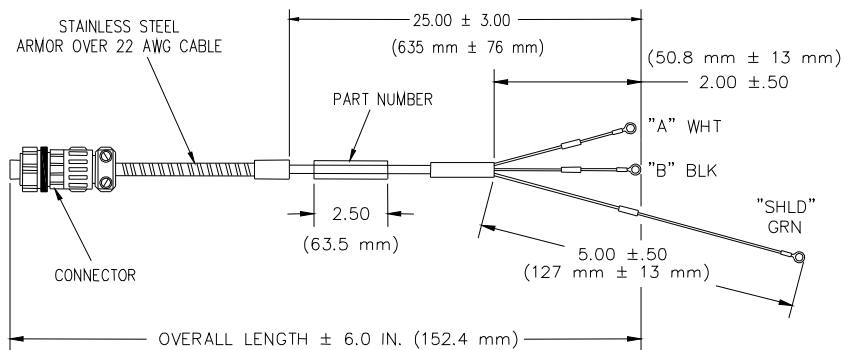

NOTE

ORDER IN INCREMENTS OF 1.0 FOOT (0.30 m)
EXAMPLE: <input type="text" value="03"/> = 3 FEET (0.91 m)
<input type="text" value="25"/> = 25 FEET (7.6 m)
MIN LENGTH = 3.0 FEET (0.91 m)
MAX LENGTH = 96 FEET (29 m)

Figure 8: Standard Armored Interconnect Cable

PART NUMBER 89477 - (SEE NOTE)

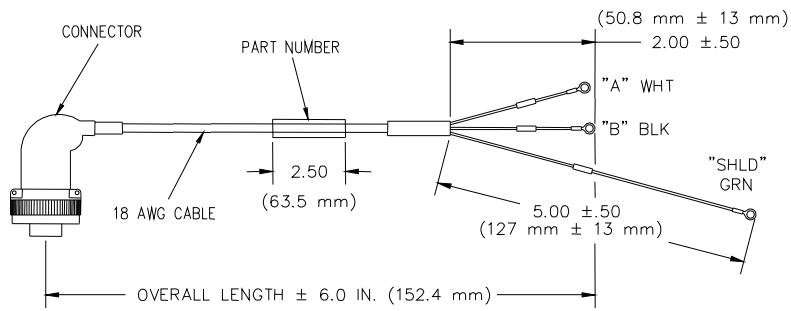

NOTE

ORDER IN INCREMENTS OF 1.0 FOOT (0.30 m)
EXAMPLE: <input type="text"/> <input type="text"/> = 2 FEET (0.60 m)
<input type="text"/> <input type="text"/> = 25 FEET (7.6 m)
MIN LENGTH = 2.0 FEET (0.60 m)
MAX LENGTH = 99 FEET (30 m)

Figure 9: Standard Right Angle Interconnect Cable

PART NUMBER 122129 – (SEE NOTE)

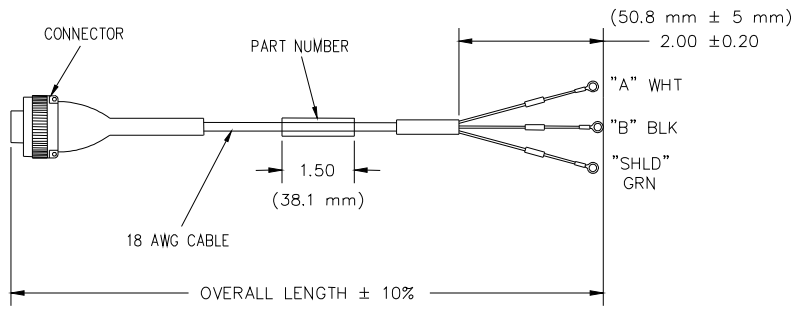

NOTE

ORDER IN INCREMENTS OF 2.0 INCHES (50.8 mm)
EXAMPLE: 06 = 6 INCHES (152 mm) 24 = 24 INCHES (610 mm)
MIN LENGTH = 6.0 INCHES (152 mm)
MAX LENGTH = 24 INCHES (610 mm)

Figure 10: Short Run Interconnect Cable

Bently Nevada, Trendmaster and Velomitor are trademarks of General Electric Company.

Copyright 2005. Bently Nevada LLC.
 1631 Bently Parkway South, Minden, Nevada USA 89423
 Phone: 775.782.3611 Fax: 775.215.2873
www.ge-energy.com/bently
 All rights reserved.