

## Bridge-Free Tooling: Floating Platform Visual Inspection Tool (Lily Pad)

# fact sheet

### Bridge-free, remote inspections to minimize critical path time

At GEH we are committed to bringing new and innovative offerings to nuclear power plants to help reduce critical path time and personnel dose exposure while improving outage performance. In support of this commitment comes the introduction of a new addition to GEH's Bridge-Free Tooling portfolio—the Floating Platform Visual Inspection Tool, also known as the “Lily Pad.” This reliable and robust new technology offering boasts a floating platform to eliminate the use of the refueling bridge or work platform when performing steam dryer outer diameter inspections.

Steam dryer inspections can be performed in parallel with fuel moves, thereby reducing critical path time and personnel dose. Inspection quality is also improved with the ability to accurately manipulate the Lily Pad with a robotic arm from a remote location in the plant, eliminating the need for a “camera handler”. The remote-controlled arm offers precision positioning for the most accurate control of the camera as opposed to traditional hand-controlled inspections typically performed from the refueling bridge. This new system is also compatible with GEH's remote R-DATA system, which allows qualified inspection technicians to remotely review and analyze real-time data collected from the site.

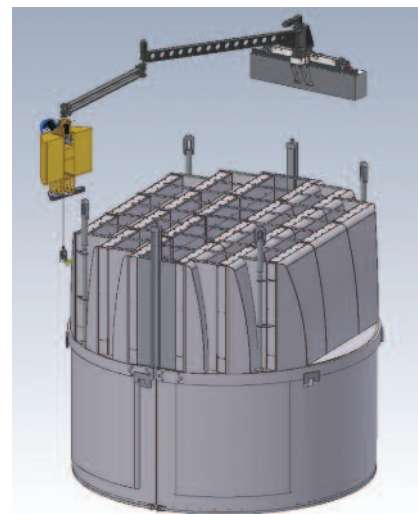
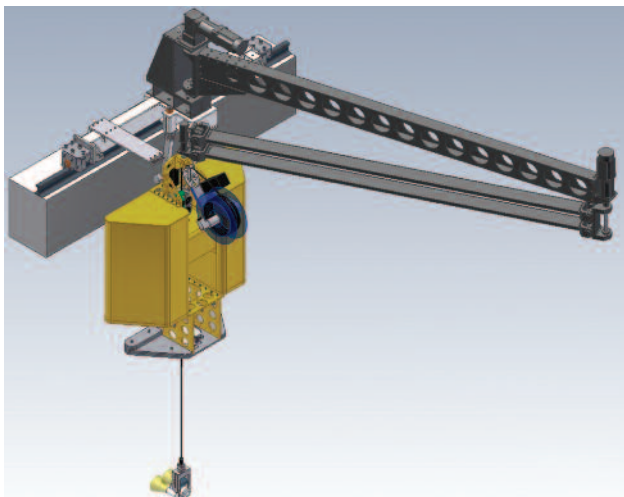

This new offering reduces radiation exposure to technicians performing visual inspections of the steam dryer from the refueling floor, as opposed to the bridge or work platform. The patented method by which the Lily Pad's robotic arm positions and manipulates the camera keeps the bridge free for parallel fuel moves during BWR 6 inspections. (Future configurations will allow use in BWR 3, 4, and 5 inspections.)



**HITACHI**

## Features

- Floating platform for bridge-free operation
- Remote operation capabilities from the refueling floor vs. work platform or bridge
- Robotic arm for easy positioning of platform
- Advanced control system allows for precise positioning of camera
- Pan/Tilt/Zoom (PTZ) equipped color camera with 25X zoom capabilities and exceptionally high quality resolutions capable of Enhanced Visual Technique-1 (EVT-1) through Visual Technique-3 (VT-3) level exams

## Benefits

- Reduced critical path time
- Improved outage productivity
- Improved quality of inspections with improved camera control
- Reduced personnel dose exposure
- Compatible with GEH's R-DATA remote data collection and analysis system



The Lily Pad allows for the visual examination of the steam dryer outer diameter from a remote location without impacting critical path refueling bridge activities.



**HITACHI**

For more information, contact your GE Hitachi Nuclear Energy sales representative or visit us at [www.ge-energy.com/nuclear](http://www.ge-energy.com/nuclear)

© 2007 GE Hitachi Nuclear Energy. All Rights Reserved.

GEA-14974A (10/07)