

POWER TRANSFORMER LIFE EXTENSION THROUGH BETTER MONITORING

Brian D. Sparling, Jacques Aubin
GE Energy

Power Transformer Reliability

Power transformers are essential components of transmission systems and often the most valuable asset in a substation. Winding construction is based on the time-proven technology of copper conductor, wrapped in cellulose insulation, and fully impregnated with insulating oil. With a Mean Time Between Failure (MTBF) above 100 years, transformers are regarded as highly dependable equipment. However, the general transformer population is now aging. This by itself would increase the risk of failure but it is compounded by the trend to load transformers to higher levels to meet economic constraints of deregulated power systems environment.

Unexpected failure is always a major disturbance in the system operation, resulting in unscheduled outages with power delivery problems. If the failure mode involves a major internal arc the tank may rupture with resulting fire and collateral damages. Replacement by a spare unit can usually be completed within a week but replacement with a new unit can take more than a year.

To reduce the risk of unexpected failure and the ensuing unscheduled outage, on-line monitoring has become the common practice to assess continuously the condition of the transformer with. Ideally, transformer monitoring should provide a continuous condition assessment against any incipient fault developing in the transformer. To meet that goal, several diagnostic methods have been developed such as: dissolved gas analysis (DGA), partial discharge (PD) detection with acoustic localization of arcing source, frequency response analysis (FRA), acoustic monitoring of tap changer etc.

Theoretically, on-line application of these methods could provide detection of anomaly, identification of the problem and assessment of the severity of the condition. In practice, selection has to be made among the various methods available. Experience has shown that most transformers will spend their life without developing any problems and it would be unproductive to maintain a host of monitoring devices whose data would only show a flat line. Economic optimization therefore requires that a simple, broadband detection method be applied as a first line of defense or early warning and that diagnostic methods be applied only on those units that have shown to be developing a problem.

Economic pressure also calls for an extension of transformer service life in addition to a reduction of maintenance costs. Fortunately, it appears that these contradictory concerns can be met to a large extent by applying state-of-the-art monitoring to these aged equipments.

Insulation Degradation Process

Selection of the most efficient monitoring system requires a review of the insulation deteriorating process and the best methods for early detection. The active parts of a transformer comprise several subsystems that are designed and tested to sustain the electric and thermal stresses occurring in normal operation. This is why most transformers will provide years of faithful service without developing any problem. However, some units submitted to unusual service conditions or suffering from manufacturing defect, excessive aging or moisture ingress may develop problems, and those problems should be detected at an early stage to allow for orderly removal from service and repair.

Transformer insulation is universally made of the time proven combination of cellulose paper or pressboard, fully impregnated with insulating oil. When the insulation is overstressed by high temperature or electric discharges, the chemical bounds within oil and cellulose molecules can be broken and new molecules will be created. Such reaction generates a variety of gasses that dissolve in the surrounding oil. Fig 1 provides an outlook of the chemical structure of insulating material and degradation by-products.

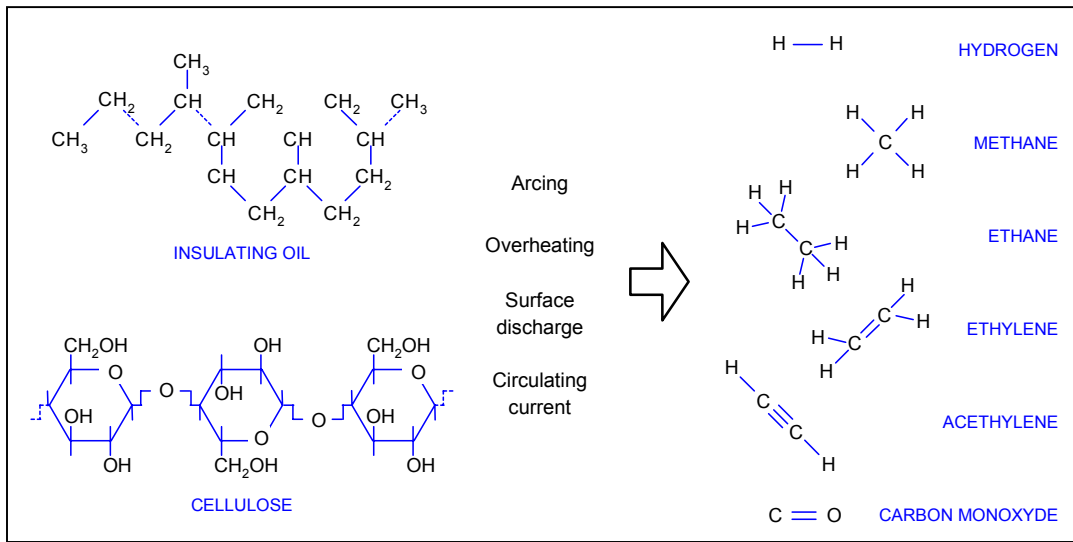

Fig. 1 Chemistry of Insulation Degradation

Any problems developing in the winding insulation, in the connections, in the core or in the shields will generate a localized high temperature or electric discharges, resulting in decomposition of oil and/or paper. The minute amount of gas dissolved in the oil can alert the operator about a problem in development and the relative proportion of each gasses can also provides indication on the type of fault. The main objective of transformer on-line monitoring is to detect these problems at an early stage to allow for orderly removal from service and repair at a minimal cost.

Detection of Dissolved Gas

Analysis of gasses dissolved in oil is the most renowned method of transformer monitoring and diagnostic. For more than 40 years, it has been a common practice to take an oil sample on a yearly basis, and send it to laboratory for a gas chromatography. In the early stage of a fault development, these gasses are created in minute amount and are measured in parts per million (ppm). Different gasses can be generated depending on the type of fault and a large body of knowledge has been developed to attempt an identification of the type and severity of the fault from the ratio of individual gasses and the rate of production of these gasses. The most common failure modes are reviewed below with the typical gas generated in each case. Individual gasses are presented and compared with the combine reading provided with the Hydran technology.

Moisture ingress in transformers tends to collect in larger amount in the cooler parts of insulating barriers at the bottom of the transformer. The proximity of ends of the windings creates a high electric field on these components. Moisture reduces the dielectric strength and can promote the occurrence of tracking discharges on the pressboard barriers that can lead to a flashover. Electric discharge of low energy will generate predominantly Hydrogen (H₂) and some Methane (CH₄).

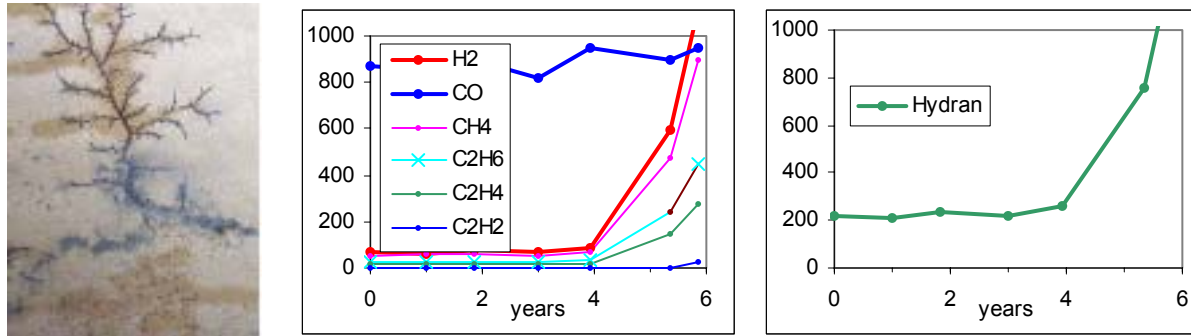

Fig. 2 Typical gasses generated in case of tracking discharge in wet insulation

The transformer core is normally insulated from tank and magnetic shields. Failure of this insulation may lead to circulating currents in the core and local overheating. These defect are known as "hot metal fault" and they produce predominantly Ethylene (C₂H₄) and Methane (CH₄) but also significant amount of Hydrogen (H₂).

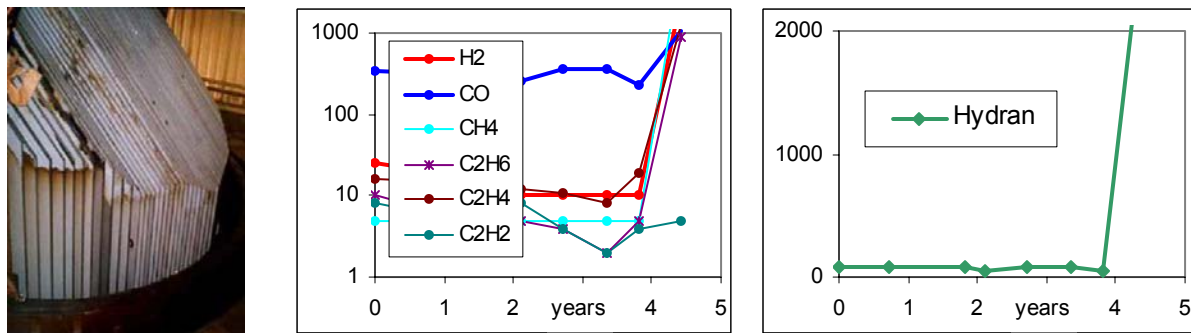

Fig. 3 Typical gasses generated in case of current circulation in the core

Degradation of crimped or brazed connection between flexible cable and rigid winding conductor often leads to a local hot spot that will initially generate some CO but later mainly Ethylene (C₂H₄) and Methane (CH₄).

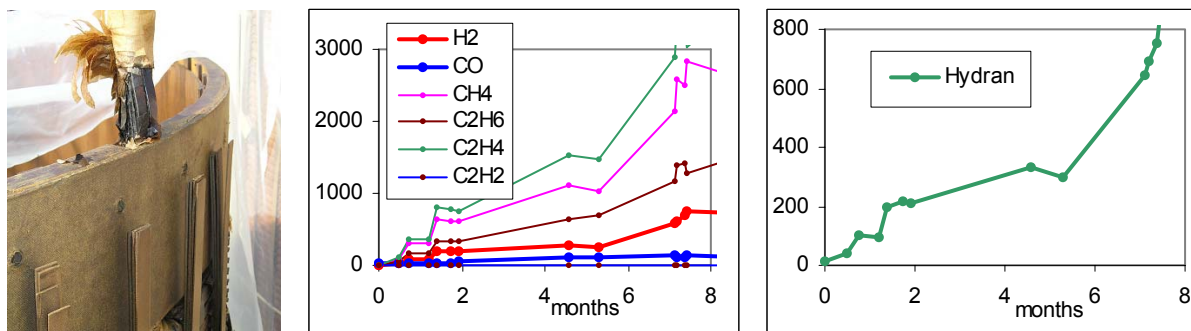

Fig. 4 Typical gasses generated in case of overheated connection

Repeated overloads or cooling system deficiency may often result in overheating of winding insulation and thermal degradation of the insulating paper. This type of fault generates mainly Carbon Monoxide (CO). This type of degradation is irreversible and determines the transformer end of life.

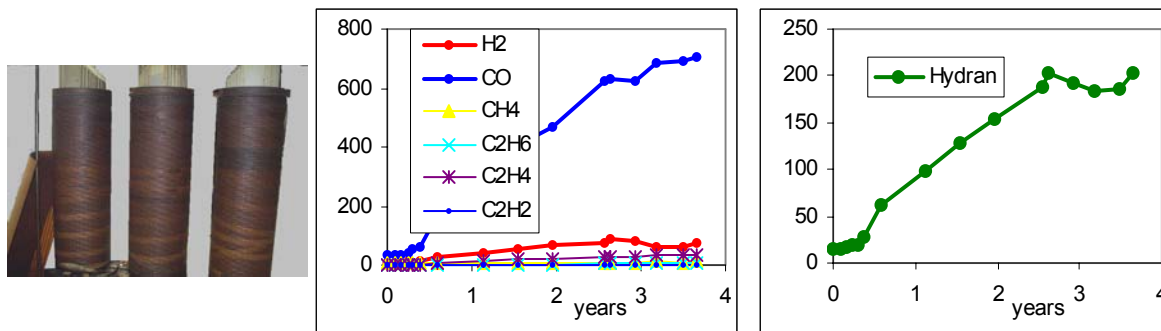

Fig. 5 Typical gasses generated in case of winding overheating

These examples show that although several gasses can be created, hydrogen and carbon monoxide are always generated in significant amounts. This is why these gasses are often used as a first line of detection for large deployment of on-line monitoring, and are often referred to as 'KEY' fault indicating gases. Hydrogen and carbon monoxide monitoring provides a wide coverage of fault detection, as they are sufficient to detect most cases of an abnormal situation developing in the transformer.

Once an alarm has been raised from the monitoring of hydrogen and carbon monoxide, several investigation tests should be carried out to determine the type of problem and the severity. Analysis of all combustible gasses is one obvious action to take once a problem has been detected but it is not needed and neither is it cost effective to use it as a first-line monitoring tool.

Monitoring vs. Diagnostic

For correct selection of transformer on-line monitoring, it is required to distinguish between fault detection and fault diagnostic. In the recent Cigre guide on transformer management¹ this distinction is skillfully summarized with an analogy to the proper approach to human health problems:

Symptoms → **Diagnosis** → **Cure**

The first step, which may be described as **monitoring** focus on detection of symptoms or evidence of abnormal condition. The fundamental question to be answered is whether the situation is normal or not. The techniques must be cost efficient and yet sufficiently sensitive and broadband to detect any potential problem at an early stage. Such monitoring techniques should be applied regularly and preferably continuously on-line.

The second step is the **diagnostic** where an abnormal situation is investigated to establish the type of fault, the severity of the problem and the corrective actions to be taken. The diagnostic step needs to be carried out only on those units that are deemed "abnormal" (usually less than 10% of the population). Tests that would be applied can be more expensive and off-line, and they need to be focused on individual attributes in an attempt to arrive at an unambiguous diagnosis. Beside the usual dissolved gas analysis (DGA), the diagnostic phase may imply a number of additional tests to assess the severity of the problem and the likely consequences if no action is taken. Examples of transformer tests that might be used include acoustic or electric partial discharge (PD), winding resistance, magnetizing currents, frequency response analysis (FRA), and polarization spectrum (recovery voltage) measurements.

This reasoning is illustrated in the logic diagram below.

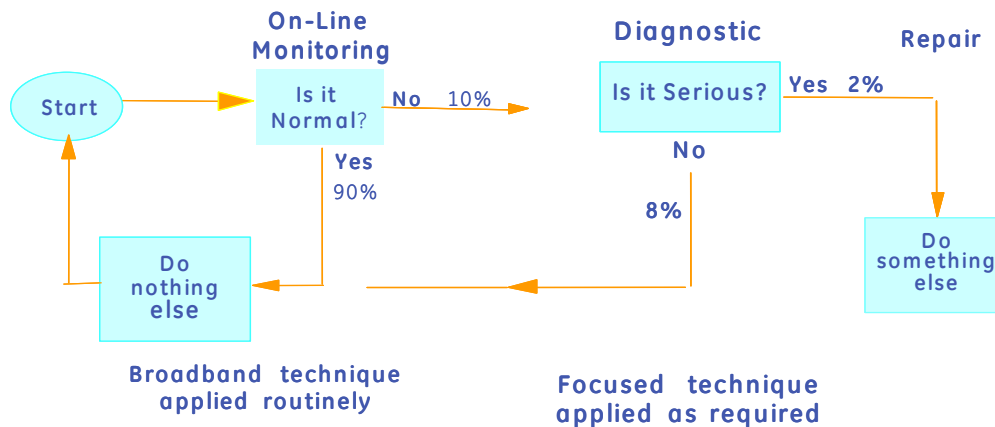

Fig.6 Monitoring vs. diagnostic logic diagram

This distinction between monitoring and diagnostic allows defining more accurately the requirements of the ideal monitoring system: it must provide a wide coverage of faults detection but it does not have to cover the full range of diagnostic and condition assessment. It would be impractical to deploy on each power transformer all the methods of interest for condition assessment.

Hydran Technology

A practical monitoring system should also be free of moving parts and ruggedized to provide years of service without any maintenance or recalibration. The Hydran technology has been developed to fulfill these requirements with a dependable and economic device, providing a wide coverage range of fault detection. The simplicity of this technology evolve from the use of a selectively permeable membrane that allows the key fault gases to come in contact with a miniature gas detector operating as a fuel cell.

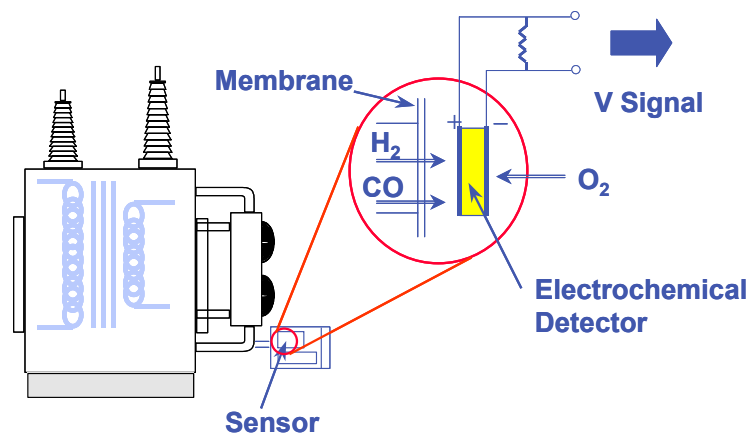

Fig. 7 Hydran technology

The high sensitivity to hydrogen allows detection of minute change in the hydrogen gas concentration. The carbon monoxide is also detected, with attenuation to 18% thus leading to a value of the same order of magnitude as the typical hydrogen content. A composite value of the two gasses, with additional traces of acetylene and ethylene, is provided and is known as the "Hydran Reading". Accurate and dependable trending of the composite value of these gasses provides a wide coverage over any type of fault

developing in the transformer tank. This technology does not require any consumable items such as helium gas, nor calibration gases for normal operation

Devices evolving from the Hydran technology are free of any moving part and connected to a single valve thus providing easy installation and safe operating conditions. These devices features automatic self-test process, twice per month, to track the operating performance of the sensor. Most recent version also includes a moisture sensor allowing calculation of moisture content in solid insulation.

Moreover this recent version also provides transformer Models allowing converting several measured values into more valuable information such as:

- Insulation hot-spot temperature calculated separately for each windings
- Insulation aging considering the type of paper, moisture content and oil preservation system
- Moisture content in winding insulation in the hot-spot area
- Threshold temperature for the release of bubbles from winding overheating
- Moisture content in insulating barriers at cool bottom oil temperature
- Cooling system efficiency and compliance with rated values
- Refined cooling system control based on load, top oil and winding temperature
- Tap changer overheating

Cost Benefit Analysis of Transformer Monitoring

Throughout the electrical industry, the need is recognized to support any significant capital investment with a cost/benefit analysis. This rule also applies to monitoring of power transformers. Calculating the cost is relatively straightforward, taking account of equipment purchase, installation, training and maintenance costs. The benefits however are more difficult to assess as the evaluation relies partly on factors dictated by experience. This exercise involves the probability of an event actually occurring, compounded by the positive or negative impact of such an event. Thus, the calculation of annualized monitoring benefits is made using on the following definitions:

Risk = Probability of occurrence of an event X Consequence of this event

Benefit = Risk without monitoring - Risk with monitoring

The most recognized benefit of early detection of incipient faults is the major savings that can be achieved on repair costs. In this respect, the purpose of monitoring is to prevent major and catastrophic failures and convert them into failures that can be repaired at a reduced cost during a planned outage. In order to evaluate the economic gain derived from deployment of on-line monitoring, the full picture of fault evolution and detection must be laid down.

It must be recognized that some of the slow-evolving faults can be detected with existing practices such as gas accumulation relay or annual gas sampling for DGA. In the example below, this efficiency (or detectability) is estimated at 30%. At the other end of the spectrum there are some failures that are instantaneous by nature and not susceptible of early detection whatever monitoring system is installed. In between are the fast-evolving faults that cannot be detected correctly by existing means but could be detected by suitable monitoring. In the example below this category of failure mode is estimated at 70%. It is on these faults that benefits can be achieved in the failure resolution cost.

The detection rate of on-line monitoring is not 100%, as some instantaneous failures will always escape detection. In the example below, this detection efficiency is estimated at 60%. It is often useful to consider separately major failures and catastrophic failures. The later involves tank rupture, fire, and consequential damage and is to be treated separately because of costly consequences. The breakdown of failure rate in different categories is depicted in Figure 8 with an example of values. This breakdown of failure is useful in the calculation of the potential benefits to be derived from transformer monitoring.

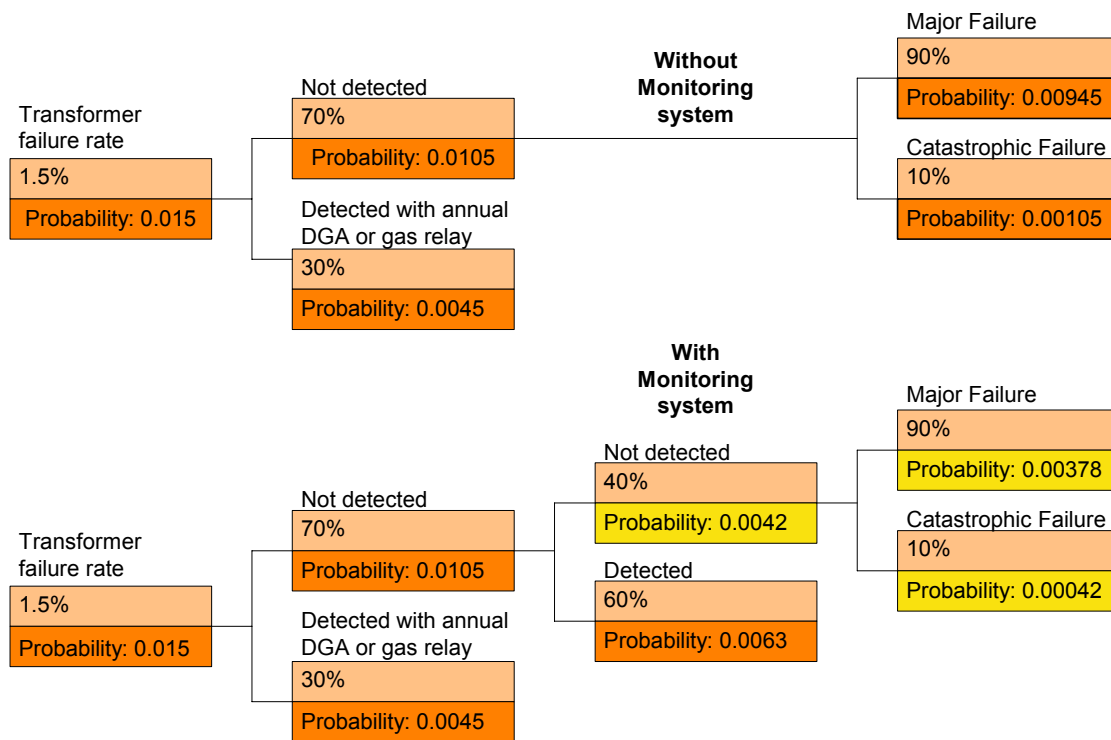

Fig. 8 Failure Probability Trees

In the example below, it is assumed that the transformer is a Generating Station Unit and the benefits to be assessed are related to failure resolutions cost and loss of generation cost. Calculation of annual savings require establishing the following costs:

Item	Description	Value
(1)	Transformer rated power	100MVA
(2)	Repair cost for major failure without any advance warning	\$1,500,000
(3)	Replacement cost and collateral damage in case of catastrophic failure	\$5,000,000
(4)	Repair cost for early detection	\$200,000
(5)	Major Failure Probability without monitoring	0.00945
(6)	Major Failure Probability with monitoring	0.00378
(7)	Catastrophic failure probability without monitoring	0.00105
(8)	Catastrophic failure probability with monitoring	0.00042
(9)	Probability of early failure detection	0.0063
(10)	Outage duration	15 days
(11)	Cost of replacement power (or penalty for not delivering)	50\$/ MWh

Without On-Line monitoring System	
Annual cost of major failure (5) x (2)	\$14 175
Annual cost of catastrophic failure (7) x (3)	\$5 250
Penalty for energy not delivered (5+7) x (1) x (10) x (11) x 24h	\$18 900
Annual cost of risk without on-line monitoring	\$38 325

With On-Line Monitoring	
Annual repair cost for major failure (6) x (2)	\$5670
Annual repair cost for catastrophic failures (8) x (3)	\$2100
Annual repair cost due to early detection (9) x (4)	\$1260
Penalty for energy not delivered (6+8) x (1) x (10) x (11) x 24h	\$7560
Annual cost of risk with on-line monitoring	\$16 590

Thus, the annual benefit for on-line monitoring is \$21 735. The payback time is calculated by comparing this annual benefit with the annualized cost of monitoring system including maintenance. This calculation method is described in more details in Cigre Technical Brochure 248² and reference 3.

In the example above, only the repair cost and energy not delivered cost have been considered. A complete analysis should include several costs / benefits items:

- Reduction of maintenance cost
- Reduction of failure resolution cost
- Cost of loss generation (for GSU)
- Cost of power not delivered (for interconnection transformers)
- Reinforcement of overload capability
- Deferring of transformer replacement

Conclusions

Transformer monitoring is becoming an essential component of transformer management. It is intended to provide an early warning for any type of fault developing in the main tank to allow operator to take further action to evaluate the severity of the situation. Monitoring devices have to be simple, dependable and cost effective. Experience has shown that a combined reading of hydrogen and carbon monoxide fulfills that need successfully.

References

1. Cigre Technical Brochure 227 "Life management techniques for power transformers" XXX 2004
2. Cigre Technical Brochure 248 "Guide on Economics of Transformer Management" June 2004
3. J. Aubin, A. Bourgault, C. Rajotte, P. Gervais, "Profitability Assessment of Transformer On-Line Monitoring and Periodic Monitoring" EPRI Substation Equipment Diagnostic Conference X, San Antonio, Texas, February 2002